



Queensland

*Heavy Vehicle National Law Act 2012*

# Heavy Vehicle (Mass, Dimension and Loading) National Regulation

Current as at 6 February 2016

**Reprint note—**

The Heavy Vehicle (Mass, Dimension and Loading) National Regulation is applied as a law of Queensland under the Heavy Vehicle National Law as applied by the *Heavy Vehicle National Law Act 2012* (Qld). This version is the regulation as it applies in Queensland. It is intended a new reprint of the regulation will be prepared by the Office of the Queensland Parliamentary Counsel when any change in the regulation takes effect.





Queensland

# Heavy Vehicle (Mass, Dimension and Loading) National Regulation

## Contents

---

		Page
<b>Part 1</b>	<b>Preliminary</b>	
1	Short title . . . . .	7
2	Commencement . . . . .	7
3	Definitions . . . . .	7
4	Meaning of section width of tyre . . . . .	14
5	Application of Regulation in relation to a retractable axle . . . . .	15
<b>Part 2</b>	<b>Mass requirements</b>	
<b>Division 1</b>	<b>Prescribed mass requirements and related provisions</b>	
6	Prescribed mass requirements . . . . .	16
7	Mass exceptions . . . . .	17
8	Limitation imposed by manufacturer's mass limits or other stated limit 17	
9	How to work out the relevant mass for a towing vehicle without a GCM 19	
10	Modified manufacturer's mass limits for a tyre relating to a particular cold inflated pressure . . . . .	20
<b>Division 2</b>	<b>CML heavy vehicle accreditation label</b>	
11	Identification requirement for particular CML heavy vehicle . . . . .	21
<b>Division 3</b>	<b>Additional provisions relating to higher mass limits</b>	
<b>Subdivision 1</b>	<b>HML declarations</b>	
12	Regulator's power to declare areas and routes for higher mass limits	21
13	Restriction on making HML declaration . . . . .	22
14	Obtaining consent of road manager . . . . .	22
15	Requirements about Commonwealth Gazette notice etc. . . . .	23
15A	Process for amending a stated map or stated list . . . . .	24
16	Contravening conditions applying to HML heavy vehicles being used in an area or on a route declared by an HML declaration . . . . .	26

Contents

---

17	Amendment or cancellation of HML declaration on Regulator’s initiative 26	
18	Amendment or cancellation of HML declaration on request by relevant road manager .....	28
19	Immediate suspension .....	30
<b>Subdivision 2</b>	<b>HML permits</b>	
20	Regulator’s power to authorise use of heavy vehicles under higher mass limits in other areas or on other routes .....	31
21	Application for HML permit .....	31
22	Restriction on grant of HML permit .....	32
23	Obtaining consent of road manager .....	32
24	Conditions of HML permit .....	32
25	Period for which HML permit applies .....	33
26	HML permit etc. ....	33
27	Refusal of application for HML permit .....	34
28	Contravening conditions of HML permit .....	34
29	Amendment or cancellation on application by HML permit holder	34
30	Amendment or cancellation of HML permit on Regulator’s initiative	36
31	Amendment or cancellation of HML permit on request by relevant road manager .....	37
32	Immediate suspension of HML permit .....	39
33	Minor amendment of HML permit .....	39
34	Return of HML permit .....	40
35	Replacement of defaced etc. HML permit .....	40
<b>Subdivision 3</b>	<b>Other provision</b>	
36	Identification requirement for particular HML heavy vehicle ....	41
<b>Part 3</b>	<b>Dimension requirements</b>	
37	Prescribed dimension requirements .....	41
<b>Part 4</b>	<b>Loading requirements</b>	
38	Loading requirements .....	42
<b>Part 5</b>	<b>Exemptions for particular overmass or oversize vehicles</b>	
<b>Division 1</b>	<b>Conditions</b>	
39	Prescribed conditions .....	42
<b>Division 2</b>	<b>Declaration of areas, roads and routes and major roads</b>	
40	Regulator may make declaration .....	43
41	Consent of relevant road manager required .....	43
42	Matters to which Regulator must have regard .....	44

43	Publication of declaration .....	45
<b>Part 6</b>	<b>Conditions for grant of mass or dimension authority imposed by relevant road manager</b>	
44	Imposition of road conditions in relation to a class 2 heavy vehicle	45
<b>Part 7</b>	<b>Reviewable decisions</b>	
45	Reviewable decisions .....	45
<b>Part 8</b>	<b>Transitional provisions</b>	
46	Saving of stated map and other matters under section 15 .....	46
<b>Schedule 1</b>	<b>General mass limits</b> .....	47
<b>Part 1</b>	<b>Imposition of general mass limits</b>	
1	General mass limits .....	47
2	Mass limits for a single vehicle or combination .....	47
3	Mass limits for a vehicle with a particular axle space less than 2.5m	49
4	Mass limits for a single axle or axle group .....	49
5	Mass limits relating to axle spacing generally .....	49
<b>Part 2</b>	<b>Axle Tables</b>	
<b>Schedule 2</b>	<b>Concessional mass limits</b> .....	74
1	Vehicles to which concessional mass limits apply .....	74
2	Concessional mass limits .....	74
<b>Schedule 4</b>	<b>Quad axle group mass exception limits</b> .....	77
1	Quad axle group mass exception limits .....	77
<b>Schedule 5</b>	<b>Higher mass limits</b> .....	78
1	Application of higher mass limits to single axle or axle group ...	78
2	Higher mass limits .....	79
<b>Schedule 5A</b>	<b>One tonne tri-axle mass transfer allowance</b> .....	81
1	One tonne tri-axle mass transfer allowance .....	81
2	Increased mass to be offset as regards the heavy vehicle .....	81
3	Axle spacing .....	82
4	Adjustments .....	82
5	Steer axles and steering axle groups excluded .....	83
<b>Schedule 6</b>	<b>Dimension requirements</b> .....	84
<b>Part 1</b>	<b>Preliminary</b>	
1	Meaning of rear overhang and rear overhang line .....	84
2	The load is part of a vehicle's dimensions .....	86
<b>Part 2</b>	<b>Heavy vehicles</b>	
3	Length—general .....	86

# Heavy Vehicle (Mass, Dimension and Loading) National Regulation

## Contents

---

4	Length—trailers . . . . .	87
5	Length—rear overhang . . . . .	90
6	Length—trailer drawbars . . . . .	90
7	Width . . . . .	91
8	Height . . . . .	92
9	Ground clearance . . . . .	92
10	Axle configuration of B-doubles . . . . .	93
<b>Part 3</b>	<b>Size and projection of loads</b>	
11	Definition for pt 3 . . . . .	94
12	In relation to rear of load . . . . .	94
13	Front and side projection of load . . . . .	95
<b>Schedule 7</b>	<b>Loading requirements</b> . . . . .	97
1	Loading . . . . .	97
<b>Schedule 8</b>	<b>Conditions of mass or dimension exemptions applying to class 1 heavy vehicles</b> . . . . .	98
<b>Part 1</b>	<b>Exemptions granted by Commonwealth Gazette notice</b>	
<b>Division 1</b>	<b>General conditions</b>	
1	Smallest practicable size of unloaded vehicle . . . . .	98
2	Warning signs and flags . . . . .	98
3	Warning lights and delineators if load projecting from vehicle . . . . .	99
4	Warning lights for wide vehicles used in daytime . . . . .	100
5	Side and rear markers and warning lights for oversize vehicles used at night . . . . .	100
6	Headlights . . . . .	101
7	Travel restrictions at night . . . . .	101
8	No travelling if low visibility . . . . .	101
9	Minimum following distance . . . . .	102
10	Allowing overtaking . . . . .	102
11	Assessing routes . . . . .	103
<b>Division 2</b>	<b>Load-carrying vehicles</b>	
12	Application of Div 2 . . . . .	103
13	Carrying goods in addition to a large indivisible item . . . . .	103
14	Towing a low loader dolly with an unladen low loader . . . . .	104
<b>Division 3</b>	<b>Special purpose vehicles</b>	
15	Application of Div 3 . . . . .	105
16	Side lights for travel at night with long front projections . . . . .	105

17	Rear marking plates and warning patterns . . . . .	105
18	Prohibition on towing other vehicles . . . . .	106
<b>Division 4</b>	<b>Agricultural vehicles</b>	
19	Application of Div 4 . . . . .	106
20	Warning devices for agricultural vehicles or combinations . . . . .	106
21	Pilot vehicle requirements for agricultural vehicles or combinations . . . . .	107
22	Agricultural vehicles or combinations not to be used on freeway . . . . .	107
23	Agricultural implements not to carry goods or passengers . . . . .	108
24	Speed limits for agricultural implements without brakes . . . . .	108
<b>Division 5</b>	<b>Pilot and escort vehicles</b>	
25	Application of Div 5 . . . . .	108
26	Requirements for a pilot vehicle . . . . .	109
27	Requirements for an escort vehicle . . . . .	109
28	Headlights on a pilot or escort vehicle . . . . .	109
29	Restriction on what a pilot or escort vehicle may carry . . . . .	110
30	Where a pilot vehicle must be driven . . . . .	110
31	Communication between drivers . . . . .	110
<b>Part 2</b>	<b>Exemptions granted by issuing a permit</b>	
32	Application of Pt 2 . . . . .	111
33	Restriction on towing other vehicles . . . . .	111
<b>Part 3</b>	<b>All mass or dimension exemptions</b>	
<b>Division 1</b>	<b>Warning lights</b>	
34	Application of Div 1 . . . . .	112
35	Characteristics of warning light . . . . .	112
36	Visibility of warning lights . . . . .	113
37	Switch for warning lights to be within easy reach . . . . .	113
38	Warning lights to be on if required, and off if not . . . . .	113
<b>Division 2</b>	<b>Warning signs</b>	
<b>Subdivision 1</b>	<b>Preliminary</b>	
39	Application of Div 2 . . . . .	114
<b>Subdivision 2</b>	<b>Class 1 heavy vehicles and pilot vehicles</b>	
40	Application of Sdiv 2 . . . . .	114
41	Face of warning sign . . . . .	114
42	Material of warning sign . . . . .	115
43	Keeping signs clean . . . . .	116
<b>Subdivision 3</b>	<b>Class 1 heavy vehicles only</b>	

# Heavy Vehicle (Mass, Dimension and Loading) National Regulation

## Contents

---

44	Application of Sdiv 3 .....	116
45	Size of warning sign .....	116
46	Face of warning sign .....	116
47	Fitting warning sign .....	117
<b>Subdivision 4</b>	<b>Pilot vehicles only</b>	
48	Application of Sdiv 4 .....	117
49	Size and shape of warning sign .....	118
50	Faces of warning sign .....	118
51	Fitting warning sign .....	119
<b>Schedule 9</b>	<b>Imposition of road conditions in relation to a class 2 heavy vehicle</b>	
	120	
<b>Schedule 10</b>	<b>Reviewable decisions</b> .....	125

---

# Heavy Vehicle (Mass, Dimension and Loading) National Regulation

## Part 1 Preliminary

### 1 Short title

This Regulation may be cited as the *Heavy Vehicle (Mass, Dimension and Loading) National Regulation*.

### 2 Commencement

This Regulation commences in a participating jurisdiction on the day on which Chapter 4 of the Law commences in that jurisdiction.

*Note—*

In this Regulation, a reference to ‘the Law’ is a reference to the Heavy Vehicle National Law. See section 12(2) of Schedule 1 of the Heavy Vehicle National Law.

### 3 Definitions

In this Regulation—

***6-tyred tandem axle group*** means a tandem axle group fitted with 6 tyres.

***ADR (Definitions and Vehicle Categories)*** means the ADR titled ‘Vehicle Standard (Australian Design Rule—Definitions and Vehicle Categories) 2005’.

***agricultural combination*** means a combination consisting of at least 1 agricultural vehicle.

***approved air suspension system***, in relation to a bus, means a suspension system in which—

- (a) vertical movement between each axle and the body of the bus is controlled by variations in the air pressure in an air spring; and

[s 3]

---

- (b) the proportion of the bus's mass borne by the air spring remains substantially constant despite variations in the air pressure in the air spring.

*centre*, of an axle group, has the same meaning as it has in section 4 of the *Heavy Vehicle (Vehicle Standards) National Regulation*.

*certified road-friendly suspension system* means a suspension system certified as a road-friendly suspension system by the Vehicle Safety Standards Branch of the Commonwealth Department of Infrastructure and Transport in accordance with the Vehicle Standards Bulletin Number 11 (revised edition) published by that branch in July 2004.

*Notes—*

- 1 A copy of the bulletin may be obtained from the website of the Commonwealth Department of Infrastructure and Transport at <[www.infrastructure.gov.au](http://www.infrastructure.gov.au)>.
- 2 At the time of publication the department was called the Department of Transport and Regional Services.

*CML heavy vehicle* means a heavy vehicle to which, or to a component of which, the concessional mass limits apply as provided by Schedule 2.

*complying bus* means a bus with 2 or 3 axles, 1 of which is a steer axle, that is fitted with an approved air suspension system and meets—

- (a) the emergency exit specifications in ADR 44; and
- (b) the rollover strength specifications in ADR 59; and
- (c) the occupant protection specifications in ADR 68.

*complying steer axle vehicle* means a heavy vehicle with a single steer axle if the vehicle has all of the following—

- (a) an engine complying with the emission control requirements contained in ADR 80/01 (Euro IV engine) or a later version of ADR 80;
- (b) a front underrun protection device that complies with UN ECE Regulation No. 93 or ADR 84—Front Underrun Impact Protection;

- (c) a cabin that complies with UN ECE Regulation No. 29;
- (d) appropriately rated tyres, axle and suspension to permit 6.5t on the steer axle;
- (e) a GVM of 15t or more.

***concessional mass limits*** means the concessional mass limits stated in section 2 of Schedule 2.

***dog trailer*** has the same meaning as it has in section 4 of the *Heavy Vehicle (Vehicle Standards) National Regulation*.

***drawbar*** has the same meaning as it has in section 4 of the *Heavy Vehicle (Vehicle Standards) National Regulation*.

***driving axle***, in relation to a vehicle, means an axle driven by the vehicle's engine.

***dual-drive tandem axle group*** means a tandem axle group consisting of 2 axles, both of which are a driving axle for a vehicle.

***front articulation point***, in relation to a trailer used in a heavy combination, means the point of articulation at the front of the trailer, which may, and may only, be any of the following—

- (a) the vertical axis of a kingpin used with a fifth wheel coupling;
- (b) the vertical axis of rotation of a fifth wheel coupling;
- (c) the vertical axis of rotation of a turntable;
- (d) in relation to a trailer that is a dog trailer, the vertical axis of rotation of the front axle group, or single axle, of the trailer;
- (e) in relation to a trailer that is a semitrailer, the imaginary vertical line passing through the pivot point for a coupling fitted to the semitrailer.

[s 3]

---

*Examples—*

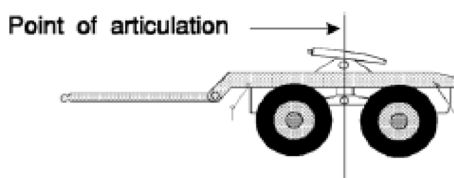

**Point of articulation—fifth wheel coupling on a converter dolly (forming the front axle group of a dog trailer)**

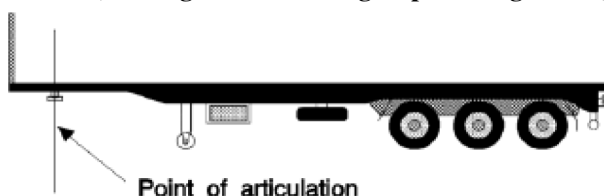

**Point of articulation—kingpin fitted to a fifth wheel coupling**

*general mass limits* has the meaning given by section 6(2).

*higher mass limits* means, in relation to a heavy vehicle to which the higher mass limits mentioned in section 1 of Schedule 5 apply as provided by the section, the higher mass limits stated in section 2 of Schedule 5.

*HML area*, in relation to an HML heavy vehicle, means an area within which the vehicle is authorised to be used under the higher mass limits under—

- (a) an HML declaration; or
- (b) an HML permit.

*HML declaration* has the meaning given by section 12(2).

*HML heavy vehicle* means a heavy vehicle to which the higher mass limits mentioned in section 1 of Schedule 5 apply as provided by the section.

*HML permit* has the meaning given by section 23(2).

*HML route*, in relation to an HML heavy vehicle, means a route on which the vehicle is authorised to be used under the higher mass limits under—

- (a) an HML declaration; or
- (b) an HML permit.

***jinker*** means a trailer—

- (a) comprising an axle or axle group built to support a load that is being transported by the trailer and its towing vehicle; and
- (b) connected to the towing vehicle by a pole or cable or the load itself, if any.

***LED technology*** means light-emitting diode technology.

***light vehicle standards*** means the standards with which a vehicle other than a heavy vehicle must comply before it may be registered under a law of a participating jurisdiction providing for the registration of vehicles other than heavy vehicles.

***load-carrying vehicle*** means a heavy vehicle carrying, or designed for the purpose of carrying, a large indivisible item, including, for example, a combination including a low loader.

***load-sharing suspension system***, of an axle group, means a suspension system—

- (a) built to divide the load between the tyres on the group so no tyre carries a mass more than 10% above the mass it would carry if the load were divided equally; and
- (b) with effective damping characteristics on all axles of the group.

***low loader*** has the same meaning as it has in section 116(4) of the Law.

***low loader dolly*** means a device for distributing mass that—

- (a) is usually coupled between a prime mover and low loader; and
- (b) consists of a rigid frame of a gooseneck shape; and
- (c) does not directly carry any load; and

(d) is equipped with 1 or more axles, a kingpin and a fifth wheel coupling.

**major road** means a road declared to be a major road for this Regulation under Division 2 of Part 5.

**mass exception** has the meaning given by section 6(3).

**one tonne tri-axle mass transfer allowance** means the mass transfer allowance stated in section 1 of Schedule 5A.

**police vehicle** means a motor vehicle driven by a police officer in the course of the police officer's duty.

**quad axle group mass exception limits** means the quad axle group mass exception limits stated in section 1 of Schedule 4.

**radial ply tyre** means a radial ply tyre within the meaning of ADR (Definitions and Vehicle Categories).

**rear overhang** has the meaning given by section 1 of Schedule 6.

**rear overhang line** has the meaning given by section 1 of Schedule 6.

**relevant accreditation label**, in relation to a CML heavy vehicle or HML heavy vehicle, means an accreditation label for a mass management accreditation issued for the vehicle under section 466 of the Law.

**relevant participating jurisdiction**, in relation to an HML declaration, means a participating jurisdiction in which the whole or part of an area or route the subject of the declaration is situated.

**relevant road manager**, in relation to an HML declaration or HML permit, means a road manager for a road in an area or on a route the subject of the declaration or permit.

**retractable axle** means an axle that can be raised so the tyres on it do not touch the ground.

**road manager consent provisions** means Division 2 of Part 4.7 of the Law.

**section width**, of a tyre, has the meaning given by section 4.

---

**single axle group** means a group of 2 or more axles in which the horizontal distance between the centre-lines of the outermost axles is less than 1m.

**single-drive axle** means a single axle that transmits automotive power.

**single-drive tandem axle group** means a tandem axle group consisting of 2 axles, only 1 of which is a driving axle for a vehicle.

**special purpose vehicle** has the same meaning as it has in section 116(4) of the Law.

**steerable axle** means a single axle that connects the wheels of a vehicle to a steering mechanism for the vehicle.

**steer axle** means the front steerable axle used to steer the vehicle.

**transport enforcement vehicle** means a motor vehicle marked as a vehicle of a road authority for a participating jurisdiction and used by the authority for the purposes of investigating or prosecuting an offence against an Australian road law.

**turntable** has the same meaning as it has in section 4 of the *Heavy Vehicle (Vehicle Standards) National Regulation*.

**ultra-low floor bus** means a bus that—

- (a) has stairless entry; and
- (b) is accessible to wheelchairs; and
- (c) is authorised to carry standing passengers.

**UN ECE Regulation** means an addendum to the United Nations Agreement Concerning the Adoption of Uniform Conditions of Approval and Reciprocal Recognition of Approval for Motor Vehicle Equipment and Parts done at Geneva on 20 March 1958.

**urban area** means an area declared to be an urban area for this Regulation under Division 2 of Part 5.

**warning light**, in Schedule 8, means a warning light complying with Division 1 of Part 3 of Schedule 8.

[s 4]

**warning pattern** means a pattern covering an area of at least 0.16m<sup>2</sup> and consisting of diagonal stripes at least 150mm wide and alternately coloured—

- (a) red and white; or
- (b) black and white.

**warning sign**, in Schedule 8, means a warning sign complying with Division 2 of Part 3 of Schedule 8.

**wheelbase**, in relation to a vehicle, means the distance from the centre line of the vehicle's foremost axle to the rear overhang line.

**yellow**, in relation to a light, includes amber.

#### 4 Meaning of **section width of tyre**

- (1) The section width of a tyre is the tyre's width worked out under subsections (2) to (4).
- (2) The tyre width of a radial ply tyre is the number of millimetres marked on the tyre in the position labelled 'section width in mm' in the following diagram—

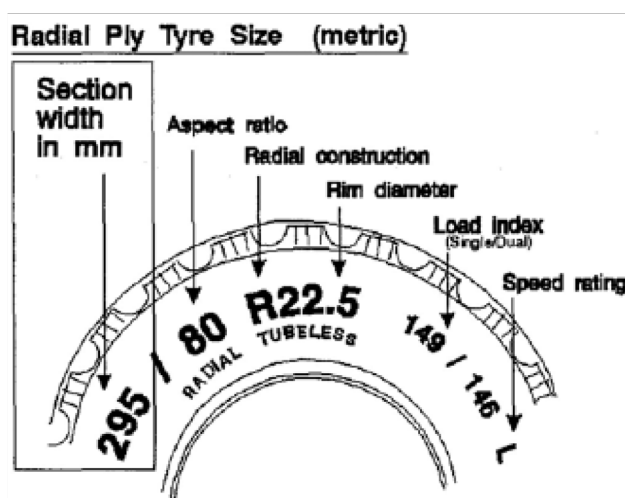

Position of section width marking on radial ply tyre

- (3) The tyre width of a bias-belted tyre is the number of millimetres equal to 25.4 times the number marked on the tyre in the position labelled 'width code in inches' in the following diagram—

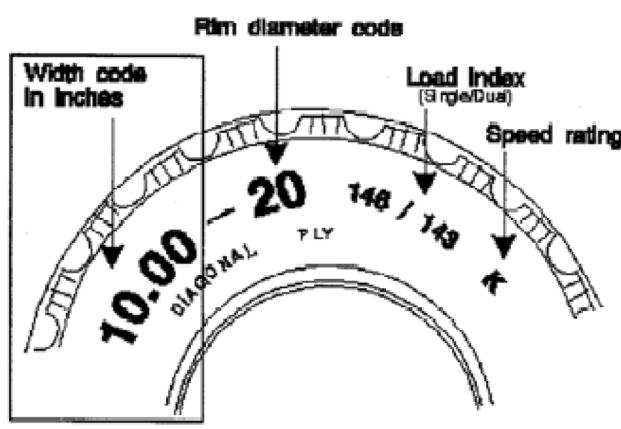

**Position of width code marking on bias-belted tyre**

- (4) The tyre width for another type of tyre is the width of the part of the tyre that normally comes into contact with the road surface.
- (5) In this section—  
*bias-belted tyre* means a bias-belted tyre within the meaning of ADR (Definitions and Vehicle Categories).

**5 Application of Regulation in relation to a retractable axle**

- (1) This section applies for the purpose of applying a provision of this Regulation in relation to a heavy vehicle that has a retractable axle if, in the circumstances to which the provision is being applied, the axle is retracted.
- (2) If the provision imposes mass limits on a single axle or axle group—  
(a) the mass limits do not apply to the retracted axle; and

[s 6]

---

- (b) the retractable axle is to be disregarded in determining whether more than 1 axle is a particular type of axle group.
- (3) If the provision imposes mass limits relating to axle spacing of a heavy vehicle, the retracted axle is to be disregarded in determining the axle spacings of the vehicle.
- (4) If the provision imposes dimension requirements in relation to distances measured by reference to a single axle or axle group, the retracted axle is to be disregarded.
- (5) In this section—  
*retracted*, in relation to an axle, means a retractable axle that is raised so that the wheels of the axle do not touch the ground.

## Part 2                      Mass requirements

### Division 1                Prescribed mass requirements and related provisions

#### 6                      Prescribed mass requirements

- (1) The mass requirements imposed by this Division and Schedules 1 to 5A are prescribed mass requirements for the purposes of section 95 of the Law.
- (2) Schedule 1 imposes mass limits that apply generally to a heavy vehicle or to components of a heavy vehicle (the *general mass limits*).
- (3) The general mass limits are subject to exceptions (each a *mass exception*) provided under section 7 and Schedules 2 to 5A in relation to a heavy vehicle or a component of a heavy vehicle.

---

*Note—*

A component, for example, may be a vehicle towing another vehicle, a vehicle being towed, a single axle, an axle group or a tyre.

- (4) Sections 8 to 10 impose requirements based on manufacturer's mass limits or other mass limits.
- (5) The prescribed mass requirements mentioned in this section apply in relation to a heavy vehicle or component whether or not the vehicle is loaded.

*Note—*

The general mass limits and mass exceptions make no distinction between a loaded or unloaded vehicle or component because an essential consideration is the mass that is applied to a road on which a heavy vehicle or component is being used.

## **7 Mass exceptions**

- (1) The mass exceptions are as follows—
  - (a) the concessional mass limits;
  - (b) the quad axle group mass exception limits;
  - (c) the higher mass limits;
  - (d) the one-tonne tri-axle mass transfer allowance.

*Note—*

See Schedules 2 to 5A for details of the mass exceptions.

- (2) A mass exception does not apply if a condition of the mass exception imposed under this Regulation is contravened.

## **8 Limitation imposed by manufacturer's mass limits or other stated limit**

- (1) Subsection (2) applies if the general mass limits or a mass exception provides for a mass limit for a heavy vehicle in excess of—
  - (a) the manufacturer's mass limits; or
  - (b) the limit stated in subsection (3) for the purposes of this paragraph.

[s 8]

---

- (2) The manufacturer's mass limits or the limit stated in subsection (3) applies and the general mass limits or mass exception does not apply.
- (3) For the purposes of subsection (1)(b), the limit is, for a combination—
  - (a) the towing vehicle of which does not have a GCM; and
  - (b) fitted with a single-drive axle, single-drive tandem axle group or dual-drive tandem axle group;the mass, in kilograms, worked out under section 9.
- (4) Subsection (5) applies if the general mass limits or a mass exception provides for a mass limit for a component of a heavy vehicle in excess of the manufacturer's mass limits for the component.
- (5) The manufacturer's mass limits for the component applies and the general mass limits or mass exception does not apply.
- (6) Subsection (7) applies if there is no general mass limits or mass exception applied to a component of a heavy vehicle under this Part other than subsection (7) and there is a manufacturer's mass limits for the component.
- (7) The manufacturer's mass limits for the component applies to the component.
- (8) In this section—

***manufacturer's mass limits***—

  - (a) in relation to a heavy vehicle, means—
    - (i) the mass limits derived from the rating set for the heavy vehicle by the vehicle's manufacturer, including the GVM or GCM stated by the manufacturer of the heavy vehicle; or
    - (ii) if the Regulator has, under section 56 of the Law, specified the total maximum loaded mass for the heavy vehicle and any vehicles it may lawfully tow—that mass; or

- (iii) if the Regulator has, under section 57 of the Law, specified the vehicle's maximum loaded mass—that mass; or
- (b) in relation to a component of a heavy vehicle, subject to section 10, means the mass limits derived from the rating set for the component by the component's manufacturer.

## 9 How to work out the relevant mass for a towing vehicle without a GCM

- (1) For the purposes of section 8(3), if the towing vehicle of a combination does not have a GCM and is fitted with a single-drive axle, single-drive tandem axle group or dual-drive tandem axle group, the mass, in kilograms, is worked out by using the following formula—

$$M = \frac{K \times TR \times R \times T}{16}$$

- (2) In the formula under subsection (1)—
- (a) **M** means mass in kilograms; and
  - (b) **K** means the following—
    - (i) if the towing vehicle is fitted with a single-drive axle—0.055;
    - (ii) if the towing vehicle is fitted with a single-drive tandem axle group—0.053;
    - (iii) if the towing vehicle is fitted with a dual-drive tandem axle group—0.051; and
  - (c) **TR** means the number of tyre revolutions per kilometre, stated by the manufacturer, of the tyres fitted to the towing vehicle's driving axles; and
  - (d) **R** means the overall gear reduction between the towing vehicle's engine and the wheels on the vehicle's driving axles; and

[s 10]

---

- (e) *T* means the towing vehicle's maximum engine net torque in newton-metres.

*Example—*

A towing vehicle does not have a GCM if—

- (a) the total maximum mass for the vehicle and any vehicles it may lawfully tow at any given time is not stated by the vehicle's manufacturer on the vehicle's identification plate or another place on the vehicle; and
- (b) the Regulator has not, under section 56 of the Law, specified the total maximum loaded mass for the vehicle and any vehicles it may lawfully tow at any given time because the vehicle has not been the subject of an application for registration or an unregistered heavy vehicle permit under the Law.

## **10 Modified manufacturer's mass limits for a tyre relating to a particular cold inflated pressure**

- (1) This section applies for the purposes of section 8.
- (2) The manufacturer's mass limits for a tyre are the manufacturer's mass limits for the tyre determined at a cold inflation pressure of not more than—
- (a) for a radial ply tyre—825kPa; or
- (b) for another type of tyre—700kPa.

*Example—*

The manufacturer's mass limits for a radial tyre are—

- at a cold inflated pressure of 200–900kPa—5t
- at a cold inflated pressure greater than 900kPa—6t.

Because the latter mass limit (6t) only applies at a cold inflated pressure above the threshold value of 825kPa mentioned in paragraph (a), the applicable manufacturer's mass limits for the tyre is 5t.

---

## **Division 2                    CML heavy vehicle accreditation label**

### **11            Identification requirement for particular CML heavy vehicle**

- (1) A person must not drive a CML heavy vehicle under the concessional mass limits unless the relevant accreditation label is maintained on the vehicle in the way required by subsections (2) to (4).

Maximum penalty—\$3000.

- (2) The relevant accreditation label must be attached in a way that the information on the label is readable from outside the CML heavy vehicle.
- (3) The relevant accreditation label must not be wholly or partly obscured, defaced or otherwise not legible.
- (4) If the CML heavy vehicle is a combination, the relevant accreditation label must be affixed to the most forward vehicle.

## **Division 3                    Additional provisions relating to higher mass limits**

### **Subdivision 1            HML declarations**

#### **12            Regulator's power to declare areas and routes for higher mass limits**

- (1) The Regulator may, by Commonwealth Gazette notice complying with section 15, declare an area in which or a route on which stated types of HML heavy vehicles are authorised to be used under the higher mass limits.
- (2) A declaration under subsection (1) is an *HML declaration*.

### **13 Restriction on making HML declaration**

- (1) The Regulator may make an HML declaration only if—
  - (a) the Regulator is satisfied the use of the stated types of HML heavy vehicles under the higher mass limits in the area or on the route will not pose a significant risk to public safety; and
  - (b) each relevant road manager for the declaration has consented to the making of the declaration; and
  - (c) the Regulator is satisfied all other consents required for the declaration have been obtained or given.
- (2) In deciding whether to make an HML declaration, the Regulator must have regard to the approved guidelines for making HML declarations.

### **14 Obtaining consent of road manager**

- (1) The road manager consent provisions apply in relation to obtaining consent of a relevant road manager for an HML declaration.
- (2) For the purposes of subsection (1)—
  - (a) a reference in the road manager consent provisions to a mass or dimension authority is taken to be a reference to an HML declaration; and
  - (b) a reference in the road manager consent provisions to the grant of a mass or dimension authority is taken to be a reference to the making of an HML declaration; and
  - (c) a reference in the road manager consent provisions to a relevant road manager for a mass or dimension authority is taken to be a reference to a relevant road manager for an HML declaration.
- (3) A relevant road manager for an HML declaration may consent to the making of the declaration subject to the condition that stated intelligent access conditions are imposed on the use of a stated type of HML heavy vehicle under the higher mass limits in an area or on a route to which the declaration applies.

- 
- (4) If a relevant road manager for an HML declaration consents to the making of the declaration as mentioned in subsection (3)—
- (a) the relevant road manager must give the Regulator written reasons for the road manager's decision to give consent to the making of the declaration subject to the condition; and
  - (b) the Regulator must include the stated intelligent access conditions in the declaration.

## **15 Requirements about Commonwealth Gazette notice etc.**

- (1) A Commonwealth Gazette notice for an HML declaration must state the following—
- (a) that HML heavy vehicles of a stated type are authorised to be used under the higher mass limits in the area or on the route stated in the notice;
  - (b) the intelligent access conditions required by a relevant road manager for the declaration under section 14(3).
- (2) Without limiting subsection (1)(a), the declaration may state the areas or routes under the subsection by—
- (a) applying by reference a stated map or stated list, not in the notice, prepared and published by the relevant road authority or the Regulator; and
  - (b) referring to the areas or routes shown on the stated map or stated list.
- (3) If the declaration applies a stated map or stated list—
- (a) the Regulator may amend the stated map or stated list prepared and published by it and the relevant road authority may amend the stated map or stated list prepared and published by it, but only by omitting, varying or extending the areas or routes mentioned in subsection (2)(b), including by adding additional areas or routes; and

[s 15A]

---

- (b) the Regulator must ensure a copy of the stated map or stated list as in force from time to time is—
  - (i) made available for inspection, without charge, during normal business hours at each office of the Regulator; and
  - (ii) published on the Regulator’s website or published by way of a reference or link published on the Regulator’s website.

*Note—*

The Regulator must publish a stated map or stated list whether the Regulator or a relevant road authority originally prepared and published it as mentioned in subsection (2).

- (4) Despite subsection (3)(a), a road authority may only amend a map or list in a way that affects a particular road if—
  - (a) the road authority is the road manager for the road; or
  - (b) the road authority is not the road manager for the road and has been advised by the Regulator that the Regulator has obtained the consent of the road manager for the amendment.
- (5) The Regulator must publish a copy of the notice on the Regulator’s website.

- (6) In this section—

*relevant road authority*, for an HML declaration, means the road authority for the participating jurisdiction in which the road likely to be travelled under the declaration is situated.

## **15A Process for amending a stated map or stated list**

- (1) This section applies to the amendment of a stated map or stated list mentioned in section 15.
- (2) For the purpose of an amendment by the Regulator only adding an additional area or route to a stated map or stated list—
  - (a) section 13 applies; and

- (b) the road manager consent provisions as applied under section 14. and section 14, apply; and
  - (c) sections 17 and 18 do not apply.
- (3) For the purpose of subsection (2), sections 13 and 14 apply as if—
- (a) a reference to the making of an HML declaration were a reference to the adding of the additional area or route; and
  - (b) a reference to the relevant road manager for an HML declaration were a reference to the relevant road manager for the declaration that applies the stated map or list.
- (4) For the purpose of an amendment by the relevant road authority only adding an additional area or route to a stated map or stated list, sections 13, 14, 17 and 18 do not apply.
- (5) For the purpose of an amendment by the Regulator or a relevant road authority if subsections (2) to (4) do not apply, sections 17 and 18 apply.
- (6) For the purpose of subsection (5), sections 17 and 18 apply as if—
- (a) a reference to the amendment of an HML declaration were a reference to the amendment of the stated map or stated list; and
  - (b) a reference to the Regulator were a reference to the Regulator or the relevant road authority, whichever is amending the stated map or stated list; and
  - (c) a reference to the relevant road manager for an HML declaration were a reference to the relevant road manager for the declaration that applies the stated map or stated list.

[s 16]

---

**16 Contravening conditions applying to HML heavy vehicles being used in an area or on a route declared by an HML declaration**

- (1) This section applies if an HML declaration states that the use of a stated type of HML heavy vehicle under the higher mass limits in an area or on a route to which the declaration applies is subject to intelligent access conditions.
- (2) A person must not use an HML heavy vehicle of the type, or permit an HML heavy vehicle of the type to be used, under the higher mass limits in an area or on a route to which the HML declaration applies unless—
  - (a) the vehicle is equipped for monitoring the relevant monitoring matters, by an approved intelligent transport system used by an intelligent access service provider; and
  - (b) the vehicle is covered by an intelligent access agreement.

Maximum penalty—\$3000.

- (3) In this section—

*intelligent access agreement* has the meaning given by section 403 of the Law.

*relevant monitoring matters* means the matters mentioned in section 402(2)(a)(i) or (ii) of the Law for the vehicle.

**17 Amendment or cancellation of HML declaration on Regulator's initiative**

- (1) It is a ground for amending or cancelling a HML declaration if the Regulator is satisfied the use of HML heavy vehicles under the higher mass limits in an area or on a route to which an HML declaration applies has caused, or is likely to cause, a significant risk to public safety.
- (2) If the Regulator considers a ground exists to amend or cancel the HML declaration, the Regulator may amend or cancel the HML declaration by complying with subsections (3) to (5).

- 
- (3) The Regulator must publish a notice in the Commonwealth Gazette, in a newspaper circulating generally throughout each relevant participating jurisdiction and on the Regulator's website—
- (a) stating the Regulator believes a ground exists to amend or cancel the HML declaration; and
  - (b) outlining the facts and circumstances forming the basis for the belief; and
  - (c) stating the action the Regulator is proposing to take under this section (the *proposed action*); and
  - (d) inviting persons who will be affected by the proposed action to make, within a stated time of at least 14 days after the Commonwealth Gazette notice is published, written representations about why the proposed action should not be taken.
- (4) If, after considering all written representations made under subsection (3)(d), the Regulator still considers a ground exists to take the proposed action, the Regulator may—
- (a) if the proposed action was to amend the HML declaration—amend the declaration, in a way that is not substantially different from the proposed action, to change the area or route to which it applies; or
  - (b) if the proposed action was to cancel the HML declaration—
    - (i) amend the declaration to change the area or route to which it applies; or
    - (ii) cancel the declaration.
- (5) Notice of the amendment or cancellation must be published—
- (a) in—
    - (i) the Commonwealth Gazette; and
    - (ii) a newspaper circulating generally throughout each relevant participating jurisdiction; and
  - (b) on the Regulator's website; and

[s 18]

---

- (c) in any other newspaper the Regulator considers appropriate.

*Example for paragraph (c)—*

If the HML declaration applies to an area or route in a particular part of a participating jurisdiction, the Regulator may consider it appropriate to publish the notice in a newspaper circulating generally in the part.

- (6) The amendment or cancellation takes effect—
  - (a) 28 days after the Commonwealth Gazette notice is published under subsection (5); or
  - (b) if a later time is stated in the Commonwealth Gazette notice, at the later time.

## **18 Amendment or cancellation of HML declaration on request by relevant road manager**

- (1) This section applies if a relevant road manager for an HML declaration is satisfied the use of HML heavy vehicles under the higher mass limits in an area or on a route to which the declaration applies (and in or on which a road for which the relevant road manager is a road manager is situated)—
  - (a) has caused, or is likely to cause, damage to road infrastructure; or
  - (b) has had, or is likely to have, an adverse effect on the community arising from noise, emissions or traffic congestion or from other matters stated in the approved guidelines; or
  - (c) has posed, or is likely to pose, a significant risk to public safety arising from heavy vehicle use that is incompatible with road infrastructure or traffic conditions.
- (2) The road manager may ask the Regulator to—
  - (a) amend the declaration to—
    - (i) change the area or route to which it applies; or

- 
- (ii) amend the intelligent access conditions applying to HML heavy vehicles used under the higher mass limits in an area or on a route to which the declaration applies; or
  - (b) cancel the declaration.
  - (3) The Regulator must comply with the request.
  - (4) However, if consent to the grant of the declaration was given by a road authority under section 163 of the Law as applied under section 14—
    - (a) the Regulator may refer the request to the road authority; and
    - (b) if the road authority gives the Regulator its written approval of the request, the Regulator must comply with the request; and
    - (c) if the road authority does not give written approval of the road manager's request within 28 days after the referral is made, the Regulator—
      - (i) must not comply with the request; and
      - (ii) must notify the road manager that the road authority has not given its written approval of the request and, as a result, the Regulator must not comply with it.
  - (5) Notice of the amendment or cancellation must be published—
    - (a) in—
      - (i) the Commonwealth Gazette; and
      - (ii) a newspaper circulating generally throughout each relevant participating jurisdiction; and
    - (b) on the Regulator's website; and
    - (c) in any other newspaper the Regulator considers appropriate.

*Example for paragraph (c)—*

If the HML declaration applies to an area or route in a particular part of a participating jurisdiction, the Regulator may consider it

[s 19]

---

appropriate to publish the notice in a newspaper circulating generally in the part.

- (6) The amendment or cancellation takes effect—
  - (a) 28 days after the Commonwealth Gazette notice is published under subsection (5); or
  - (b) if a later time is stated in the Commonwealth Gazette notice, at the later time.

## 19 Immediate suspension

- (1) This section applies if—
  - (a) the Regulator considers a ground exists to cancel an HML declaration; or
  - (b) the Regulator reasonably believes it is necessary to suspend the declaration immediately to prevent or minimise serious harm to public safety or significant damage to road infrastructure.
- (2) The Regulator may, by publishing a notice as mentioned in subsection (3) (*immediate suspension notice*), immediately suspend the declaration until the earlier of the following—
  - (a) the Regulator publishes a notice under section 17(5) or 18(5);
  - (b) the Regulator cancels the suspension;
  - (c) the end of 56 days after the day the immediate suspension notice is published.
- (3) The immediate suspension notice, and (where relevant) the cancellation of the suspension, must be published—
  - (a) in—
    - (i) the Commonwealth Gazette; and
    - (ii) a newspaper circulating generally throughout each relevant participating jurisdiction; and
  - (b) on the Regulator’s website; and

- (c) in any other newspaper the Regulator considers appropriate.

*Example for paragraph (c)—*

If the HML declaration applies to an area or route in a particular part of a participating jurisdiction, the Regulator may consider it appropriate to publish the notice in a newspaper circulating generally in the part.

- (4) The suspension, and (where relevant) the cancellation of the suspension, takes effect immediately after the Commonwealth Gazette notice is published under subsection (3).
- (5) This section applies despite sections 17 and 18.

## **Subdivision 2 HML permits**

### **20 Regulator's power to authorise use of heavy vehicles under higher mass limits in other areas or on other routes**

- (1) The Regulator may, by giving a person a permit as mentioned in section 26, authorise, for a period of not more than 3 years, the use of an HML heavy vehicle under the higher mass limits in stated areas or on stated routes.
- (2) A permit under subsection (1) is an *HML permit*.
- (3) An HML permit may apply to 1 or more HML heavy vehicles.

### **21 Application for HML permit**

- (1) A person may apply to the Regulator for an HML permit.
- (2) The application must be—
- (a) in the approved form; and
  - (b) accompanied by the prescribed fee for the application.
- (3) The Regulator may, by notice given to the applicant, require the applicant to give the Regulator any additional information the Regulator reasonably requires to decide the application.

## **22 Restriction on grant of HML permit**

- (1) The Regulator may grant an HML permit for an HML heavy vehicle only if—
  - (a) the Regulator is satisfied the use of the vehicle under the higher mass limits in the area or on the route to which the permit will apply will not pose a significant risk to public safety; and
  - (b) each relevant road manager for the permit has consented to the grant of the permit; and
  - (c) the Regulator is satisfied all other consents required for the grant of the permit have been obtained or given.
- (2) In deciding whether to grant an HML permit for an HML heavy vehicle, the Regulator must have regard to the approved guidelines for granting HML permits.

## **23 Obtaining consent of road manager**

- (1) The road manager consent provisions apply in relation to obtaining the consent of a relevant road manager for the grant of an HML permit.
- (2) For the purposes of subsection (1)—
  - (a) a reference in the road manager consent provisions to a mass or dimension authority is taken to be a reference to an HML permit; and
  - (b) a reference in the road manager consent provisions to the grant of a mass or dimension authority is taken to be a reference to the grant of an HML permit; and
  - (c) a reference in the road manager consent provisions to a relevant road manager for a mass or dimension authority is taken to be a reference to a relevant road manager for an HML permit.

## **24 Conditions of HML permit**

- (1) An HML permit—

- 
- (a) must be subject to the road conditions or travel conditions required by a relevant road manager for the permit; and
  - (b) may be subject to any other conditions the Regulator considers appropriate, including, for example—
    - (i) conditions about 1 or more matters mentioned in Schedule 2 of the Law; and
    - (ii) without limiting subparagraph (i), intelligent access conditions.
- (2) However, a condition imposed under subsection (1) must be consistent with the higher mass limits.

## **25 Period for which HML permit applies**

- (1) An HML permit applies for the period stated in the permit.
- (2) The period may be less than the period sought by the applicant for the HML permit.

## **26 HML permit etc.**

- (1) If the Regulator grants an HML permit to a person, the Regulator must give the person—
  - (a) an HML permit; and
  - (b) if the Regulator has imposed conditions on the permit under section 24 or has granted the permit for a period less than the period of not more than 3 years sought by the person—an information notice for the decision to impose the conditions or grant the permit for the shorter period.
- (2) The permit must state the following—
  - (a) the name and address of the person to whom the permit is given;
  - (b) a description of—

[s 27]

---

- (i) the HML heavy vehicle or vehicles to which the permit applies, including the registration number of the vehicle if it is registered; or
- (ii) if the permit applies to particular categories of class 2 heavy vehicles—the categories of heavy vehicles to which the permit applies;
- (c) the areas or routes to which the permit applies;
- (d) the road conditions or travel conditions required by a relevant road manager for the permit;
- (e) any other conditions applying to an HML heavy vehicle while it is being used under the permit;
- (f) the period for which the permit applies.

## **27 Refusal of application for HML permit**

If the Regulator refuses an application for an HML permit, the Regulator must give the applicant an information notice for the decision to refuse the application.

## **28 Contravening conditions of HML permit**

The driver or operator of an HML heavy vehicle being used under the higher mass limits under an HML permit must not contravene a condition of the permit.

Maximum penalty—\$3000.

## **29 Amendment or cancellation on application by HML permit holder**

- (1) The holder of an HML permit may apply to the Regulator for an amendment or cancellation of the permit.
- (2) The application must—
  - (a) be in writing; and
  - (b) be accompanied by the prescribed fee for the application; and

- (c) if the application is for an amendment, state clearly the amendment sought and the reasons for the amendment; and
  - (d) be accompanied by the permit.
- (3) The Regulator may, by notice given to the applicant, require the applicant to give the Regulator any additional information the Regulator reasonably requires to decide the application.
- (4) If the proposed amendment of the permit is—
  - (a) to amend the areas or routes to which the permit applies (other than by omitting an area or route or reducing an area or route in size); or
  - (b) to impose or amend road conditions or travel conditions; then—
    - (c) the Regulator must ask the relevant road managers (for the roads to which the amendment relates) for their consent to the amendment; and
    - (d) the road manager consent provisions apply to the request for consent in the same way as they apply to a request for consent under those provisions, with necessary modifications.
- (5) The Regulator must decide the application as soon as practicable after receiving it.
- (6) If the Regulator decides to grant the application—
  - (a) the Regulator must give the applicant notice of the decision; and
  - (b) the amendment or cancellation takes effect—
    - (i) when notice of the decision is given to the applicant; or
    - (ii) if a later time is stated in the notice, at the later time; and
  - (c) if the Regulator amended the permit, the Regulator must give the applicant a replacement permit for the permit as amended.

[s 30]

---

- (7) If the Regulator decides not to amend or cancel the permit as sought by the applicant, the Regulator must—
  - (a) give the applicant an information notice for the decision; and
  - (b) return the permit to the applicant.

### **30 Amendment or cancellation of HML permit on Regulator's initiative**

- (1) Each of the following is a ground for amending or cancelling an HML permit—
  - (a) the permit was granted because of a document or representation that was—
    - (i) false or misleading; or
    - (ii) obtained or made in an improper way;
  - (b) the holder of the permit has contravened a condition of the permit;
  - (c) the use of HML heavy vehicles under the higher mass limits in an area or on a route the subject of the permit has caused, or is likely to cause, a significant risk to public safety.
- (2) If the Regulator considers a ground exists to amend or cancel an HML permit (the *proposed action*), the Regulator must give the holder of the permit a notice—
  - (a) stating the proposed action; and
  - (b) stating the ground for the proposed action; and
  - (c) outlining the facts and circumstances forming the basis for the ground; and
  - (d) if the proposed action is to amend the permit (including a condition of the permit)—stating the proposed amendment; and
  - (e) inviting the holder to make, within a stated time of at least 14 days after the notice is given to the holder,

---

written representations about why the proposed action should not be taken.

- (3) If, after considering all written representations made under subsection (2)(e), the Regulator still considers a ground exists to take the proposed action, the Regulator may—
  - (a) if the proposed action was to amend the HML permit—amend the permit in a way that is not substantially different from the proposed action, including, for example, by—
    - (i) amending the areas or routes to which the permit applies; or
    - (ii) imposing additional conditions on the permit; or
  - (b) if the proposed action was to cancel the HML permit—
    - (i) amend the permit, including, for example, as mentioned in paragraph (a)(i) or (ii); or
    - (ii) cancel the permit.
- (4) The Regulator must give the holder an information notice about the decision.
- (5) The amendment or cancellation takes effect—
  - (a) when the information notice is given to the holder; or
  - (b) if a later time is stated in the information notice, at the later time.

### **31 Amendment or cancellation of HML permit on request by relevant road manager**

- (1) This section applies if a relevant road manager for an HML permit is satisfied the use of HML heavy vehicles under the higher mass limits in an area or on a route to which the permit applies (and in or on which is situated a road for which the relevant road manager is a road manager)—
  - (a) has caused, or is likely to cause, damage to road infrastructure; or

[s 31]

---

- (b) has had, or is likely to have, an adverse effect on the community arising from noise, emissions or traffic congestion or from other matters stated in approved guidelines; or
  - (c) has posed, or is likely to pose, a significant risk to public safety arising from heavy vehicle use that is incompatible with road infrastructure or traffic conditions.
- (2) The road manager may ask the Regulator to—
- (a) amend the HML permit, including, for example, by—
    - (i) amending the areas or routes to which the permit applies; or
    - (ii) imposing or amending road conditions on the permit; or
  - (b) cancel the permit.
- (3) The Regulator must comply with the request.
- (4) However, if consent to the grant of the permit was given by a road authority under section 163 of the Law—
- (a) the Regulator may refer the request to the road authority; and
  - (b) if the road authority gives the Regulator its written approval of the request, the Regulator must comply with the request; and
  - (c) if the road authority does not give written approval of the road manager's request within 28 days after the referral is made, the Regulator—
    - (i) must not comply with the request; and
    - (ii) must notify the road manager that the road authority has not given its written approval of the request and, as a result, the Regulator must not comply with it.
- (5) If the permit is amended or cancelled under this section, the Regulator must give the holder of the HML permit notice of

---

the amendment or cancellation at least 28 days before the amendment or cancellation is to take effect.

- (6) The notice given to the holder must state—
- (a) the day the amendment or cancellation is to take effect; and
  - (b) the reasons given by the relevant road manager for the amendment or cancellation; and
  - (c) the review and appeal information for the road manager's decision.

### **32 Immediate suspension of HML permit**

- (1) This section applies if—
- (a) the Regulator considers a ground exists to cancel an HML permit; or
  - (b) the Regulator reasonably believes it is necessary to suspend the permit immediately to prevent or minimise serious harm to public safety or significant damage to road infrastructure.
- (2) The Regulator may, by notice (*immediate suspension notice*) given to the holder of the permit, immediately suspend the permit until the earlier of the following—
- (a) the Regulator gives the person a notice under section 30(4) or 31(5);
  - (b) the Regulator cancels the suspension;
  - (c) the end of 56 days after the day the immediate suspension notice is given to the person.
- (3) This section applies despite sections 29, 30 and 31.

### **33 Minor amendment of HML permit**

- (1) The Regulator may, by notice given to the holder of an HML permit, amend the permit in a minor respect—
- (a) for a formal or clerical reason; or

[s 34]

---

- (b) in another way that does not adversely affect the holder's interests.
- (2) The Regulator must provide the relevant road manager with notice of the amendment.

### **34 Return of HML permit**

- (1) If a person's HML permit is amended or cancelled, the Regulator may, by notice, require the person to return the permit to the Regulator.
- (2) The person must comply with the notice within 7 days after the notice is given to the person or, if a longer period is stated in the notice, within the longer period.  
Maximum penalty—\$4000.
- (3) If the HML permit has been amended, the Regulator must give the person a replacement permit as amended.

### **35 Replacement of defaced etc. HML permit**

- (1) If a person's HML permit is defaced, destroyed, lost or stolen, the person must, as soon as reasonably practicable after becoming aware of the matter, apply to the Regulator for a replacement permit.  
Maximum penalty—\$4000.
- (2) If the Regulator is satisfied the HML permit has been defaced, destroyed, lost or stolen, the Regulator must give the person a replacement permit as soon as practicable.
- (3) If the Regulator decides not to give a replacement permit to the person, the Regulator must give the person an information notice for the decision.

---

## **Subdivision 3      Other provision**

### **36      Identification requirement for particular HML heavy vehicle**

- (1) This section applies to an HML heavy vehicle that—
  - (a) is fitted with or, if it is a combination, has a component vehicle fitted with, a tri-axle group; and
  - (b) is used on a road in an HML area, or on an HML route, for the vehicle.
- (2) A person must not drive the HML heavy vehicle under the higher mass limits unless the relevant accreditation label is maintained on the vehicle in the way required by subsections (3) to (5).

Maximum penalty—\$3000.
- (3) The relevant accreditation label must be attached in a way that the information on the label is readable from outside the HML heavy vehicle.
- (4) The relevant accreditation label must not be wholly or partly obscured, defaced or otherwise not legible.
- (5) If the HML heavy vehicle is a combination, the relevant accreditation label must be affixed to the most forward vehicle.

## **Part 3                      Dimension requirements**

### **37      Prescribed dimension requirements**

- (1) The dimension requirements imposed by Schedule 6 are prescribed dimension requirements for the purposes of section 101 of the Law.
- (2) The prescribed dimension requirements apply to a heavy vehicle whether or not the vehicle is loaded.

## **Part 4 Loading requirements**

### **38 Loading requirements**

The loading requirements applying to a heavy vehicle are stated in Schedule 7.

## **Part 5 Exemptions for particular overmass or oversize vehicles**

### **Division 1 Conditions**

#### **39 Prescribed conditions**

- (1) The conditions stated in Part 1 of Schedule 8 are conditions of a mass or dimension exemption applying to a class 1 heavy vehicle granted by Commonwealth Gazette notice.
- (2) The conditions stated in Part 2 of Schedule 8 are conditions of a mass or dimension exemption applying to a class 1 heavy vehicle granted by issuing a permit to a person.
- (3) The conditions stated in Division 1 of Part 3 of Schedule 8 are conditions of a mass or dimension exemption applying to a class 1 heavy vehicle granted by issuing a permit to a person if the exemption is subject to the condition that the heavy vehicle, or a pilot vehicle or escort vehicle accompanying the heavy vehicle, must have warning lights.
- (4) The conditions stated in Division 2 of Part 3 of Schedule 8 are conditions of a mass or dimension exemption applying to a class 1 heavy vehicle granted by issuing a permit to a person if the exemption is subject to the condition that the heavy vehicle, or a pilot vehicle accompanying the heavy vehicle, must have a warning sign.
- (5) A condition mentioned in subsections (1) to (4)—

- (a) applies unless the notice or permit mentioned in the subsection provides otherwise; and
- (b) applies to a class 1 heavy vehicle, or a pilot vehicle or escort vehicle accompanying a class 1 heavy vehicle, to which a mass or dimension exemption applies while the class 1 heavy vehicle is being used under the exemption.

## **Division 2                      Declaration of areas, roads and routes and major roads**

### **40            Regulator may make declaration**

The Regulator may, by Commonwealth Gazette notice, declare—

- (a) categories of areas, roads and routes for the purpose of imposing conditions under section 119(1) or 125(1) of the Law; or
- (b) a road to be a major road for the purposes of this Regulation.

### **41            Consent of relevant road manager required**

- (1) The Regulator may make a declaration under section 40 only if each relevant road manager for the declaration has consented to the making of the declaration.
- (2) The road manager consent provisions apply in relation to obtaining consent of a road manager for a road for a declaration under section 40.
- (3) For the purposes of subsection (2)—
  - (a) a reference in the road manager consent provisions to a mass or dimension authority is taken to be a reference to a declaration under section 40; and
  - (b) a reference in the road manager consent provisions to the grant of a mass or dimension authority is taken to be

a reference to the making of a declaration under section 40; and

- (c) a reference in the road manager consent provisions to a road manager for a relevant road for a mass or dimension authority is taken to be a reference to a relevant road manager for a declaration under section 40.

- (4) In this section—

*relevant road manager* means—

- (a) for a declaration under section 40(a)—a road manager for a road, or a road on the route, or in the area, the subject of the declaration; or
- (b) for a declaration under section 40(b)—the road manager for the road the subject of the declaration.

## **42 Matters to which Regulator must have regard**

- (1) In deciding whether to make a declaration under section 40, the Regulator must have regard to the following—
  - (a) the type of each affected road, including, for example, whether it is an arterial road;
  - (b) the volume of traffic on each affected road;
  - (c) the capacity of each affected road to accommodate wide vehicles;
  - (d) relevant environmental conditions for each affected road, including, for example, visibility of road users;
  - (e) any other matter the Regulator considers appropriate.
- (2) In this section—

*affected road*, for a declaration under section 40, means a road affected by the declaration.

#### **43 Publication of declaration**

The Regulator must publish on its website a copy of each declaration made under section 40.

## **Part 6 Conditions for grant of mass or dimension authority imposed by relevant road manager**

#### **44 Imposition of road conditions in relation to a class 2 heavy vehicle**

- (1) This section applies for the purposes of section 160(4) of the Law.
- (2) The kinds of road conditions prescribed for section 160(1)(b) of the Law and the circumstances in which it is appropriate to impose those conditions are in Schedule 9.

## **Part 7 Reviewable decisions**

#### **45 Reviewable decisions**

- (1) Each decision mentioned in Schedule 10 is a reviewable decision for Chapter 11 of the Law.
- (2) The dissatisfied person for a reviewable decision mentioned in Schedule 10 is each person who is adversely affected by the decision.

## Part 8 Transitional provisions

### 46 Saving of stated map and other matters under section 15

- (1) Subsections (2) to (4) apply to the following—
  - (a) a stated map applied under unamended section 15(2) in an HML declaration in existence immediately before the commencement;
  - (b) the areas or routes shown on the stated map immediately before the commencement;
  - (c) a list of areas or routes applied, adopted or incorporated under section 24(1) of Schedule 1 of the Law in an HML declaration in existence immediately before the commencement.
- (2) The stated map is taken to be a stated map applied under amended section 15(2).
- (3) The list of areas or routes is taken to be a stated list applied under amended section 15(2).
- (4) The areas or routes shown on the stated map mentioned in subsection (2) or the stated list mentioned in subsection (3) may only be amended under amended section 15 and section 15A.
- (5) In this section—

*amended section 15* means section 15 as amended by the amendment regulation.

*amendment regulation* means the *Heavy Vehicle National Amendment Regulation 2015*.

*commencement* means the commencement of the amendment of section 15 under the amendment regulation.

*unamended section 15* means section 15 as it existed immediately before it was amended by the amendment regulation.

---

## Schedule 1      General mass limits

section 6(2)

### Part 1                      Imposition of general mass limits

#### 1      General mass limits

- (1) The mass limits stated in this Schedule apply to a heavy vehicle or a component of a heavy vehicle.
- (2) If, in relation to a particular vehicle or component, this Schedule provides for 2 or more mass limits imposing different mass limits that apply in the same circumstances, the lower or lowest mass limit applies and the other mass limit or mass limits must be disregarded.

#### 2      Mass limits for a single vehicle or combination

- (1) The mass of a single vehicle or combination must not be more than the lower of the following masses—
  - (a) the mass that is the lower or lowest of the following—
    - (i) for a complying bus without a trailer—
      - (A) if the bus has only 2 axles—16t; or
      - (B) if the bus has a rear tandem axle group fitted with single tyres on 1 axle and dual tyres on the other axles—20t; or
      - (C) if the bus has a rear tandem axle group fitted with dual tyres on all axles—22.5t;
    - (ii) for a complying bus with a trailer, the sum of—
      - (A) the mass limits for the bus mentioned in subparagraph (i); and

- (B) the mass that is the sum of the mass limits applying to the trailer's axle groups and single axles under Table 1 of Part 2;
  - (iii) for a bus that is an ultra-low floor bus with no axle groups and only 2 single axles—16t;
  - (iv) for a complying steer axle vehicle that is neither a B-double nor a road train—43t;
  - (v) for a vehicle that is not mentioned in subparagraphs (i) to (iv) and that is neither a B-double nor a road train—42.5t;
  - (b) the mass that is the sum of the mass limits stated in Table 1 of Part 2 in relation to each of the axle groups and single axles of the single vehicle or combination.
- (2) A vehicle is not within the amount of the mass stated in subsection (1)(b) if any single axle or axle group fitted to the vehicle has a mass in excess of the mass limits applying to the single axle or axle group.
- (3) The purpose of subsection (2) is to ensure that a vehicle cannot be brought within the mass stated in subsection (1)(b) by off-setting an under limit mass on an axle group or single axle against an over limit mass on another axle group or single axle.
- (4) In a combination, the mass of a dog trailer or pig trailer must not be more than the mass of the towing vehicle.
- (5) In this section—

***over limit mass*** means the amount by which the mass on an axle group or single axle of a vehicle is more than the mass stated in relation to the axle group or single axle in Table 1 of Part 2.

***single vehicle*** means a heavy motor vehicle that is not towing another vehicle.

***under limit mass*** means the amount by which the mass on an axle group or single axle of a vehicle is less than the mass stated for the axle group or single axle in Table 1 of Part 2.

---

**3 Mass limits for a vehicle with a particular axle space less than 2.5m**

If the distance between any 2 axles on a heavy vehicle that are not part of the same axle group is less than 2.5m, the mass of the heavy vehicle must not be more than 15t.

**4 Mass limits for a single axle or axle group**

The mass on a single axle or axle group must not be more than the mass limit stated in relation to the single axle or axle group in Table 1 of Part 2.

**5 Mass limits relating to axle spacing generally**

- (1) The mass of a heavy vehicle, other than a road train or a B-double, relating to an axle spacing of the vehicle must not be more than—
  - (a) the mass limit stated in Table 2 of Part 2 in relation to the axle spacing; or
  - (b) if—
    - (i) the heavy vehicle is a complying steer axle vehicle; and
    - (ii) the steer axle is used to calculate the axle spacing mentioned in paragraph (a)—

the mass limit mentioned in paragraph (a) increased by 0.5t.
- (2) The mass of a B-double relating to an axle spacing of the B-double must not be more than—
  - (a) the mass limit stated in Table 3 of Part 2 in relation to the axle spacing; or
  - (b) if—
    - (i) the B-double is a complying steer axle vehicle; and
    - (ii) the steer axle is used to calculate the axle spacing mentioned in paragraph (a)—

the mass limit mentioned in paragraph (a) increased by 0.5t.

- (3) The mass of a road train relating to an axle spacing of the road train must not be more than the mass limit stated in Table 4 of Part 2 in relation to the axle spacing.
- (4) Each of the following is an axle spacing of a heavy vehicle—
  - (a) the distance from the centre-line of a single axle to the centre-line of another single axle;
  - (b) the distance from the centre-line of a single axle to the centre-line of the furthest axle in any axle group;
  - (c) the greatest distance between the centre-lines of axles in any 2 axle groups.

*Examples—*

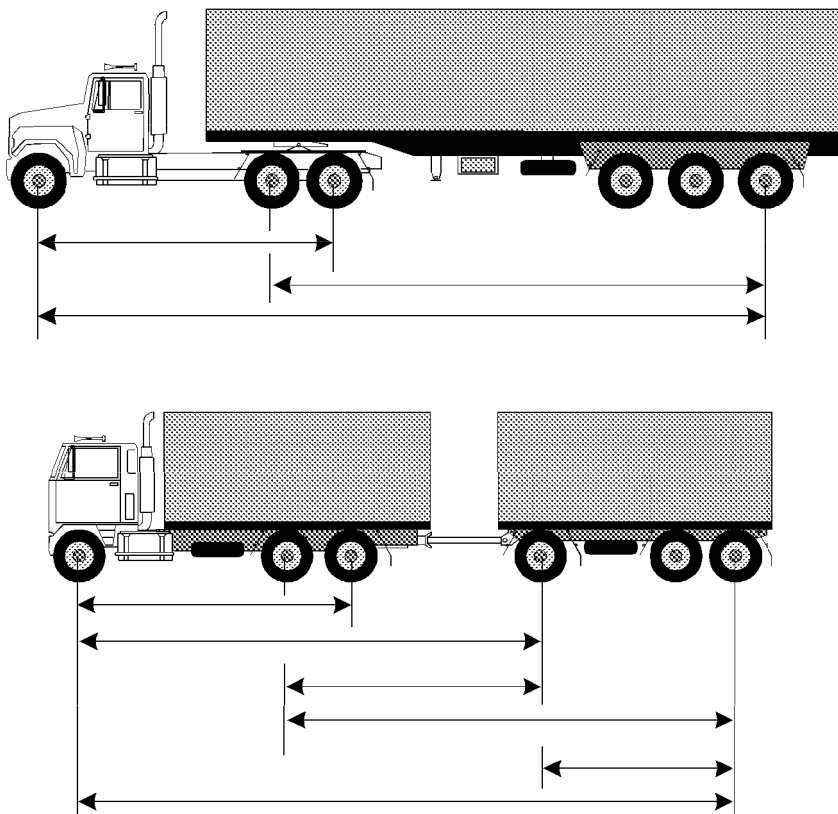

**Axle spacings of a heavy vehicle**

- (5) The mass limits imposed by subsections (1) to (3) apply to the sum of the mass on each axle group or single axle within the heavy vehicle’s axle spacing.
- (6) The axle groups or single axles that are within an axle spacing of a heavy vehicle are the end axles and every axle group or single axle between the end axles.

*Example—*

In the examples under subsection (4), for the longest axle space, the mass limits imposed by subsections (1) to (3) apply to the sum of the mass on each of the axle groups or single axles made up of the 6 axles shown as included within the spacing.

(7) In this section—

*end axles*, in relation to an axle spacing, are the axle groups or single axles on each end of the axle spacing.

## Part 2 Axle Tables

Table 1—Axle mass limits table

Description of single axle or axle group	Mass limit (t)
<b>Single axles and single axle groups</b>	
Steer axles on—	
(a) a complying bus	6.5
(aa) a complying steer axle vehicle	6.5
(b) a hauling unit or prime mover forming part of a road train fitted with tyres with section widths of—	
(i) at least 295mm	6.5
(ii) at least 375mm	6.7
(c) another motor vehicle	6.0
Single axle or single axle group fitted with single tyres with section widths of—	
(a) less than 375mm	6.0
(b) at least 375mm but less than 450mm	6.7
(c) at least 450mm	7.0
Single axle or single axle group fitted with dual tyres on—	
(a) a pig trailer	8.5
(b) a complying bus, or a bus authorised to carry standing passengers under an Australian road law	10.0

<b>Description of single axle or axle group</b>	<b>Mass limit (t)</b>
(c) an ultra-low floor bus with no axle groups and only 2 single axles	11.0
(d) another vehicle	9.0
<b>Tandem axle group</b>	
Tandem axle group fitted with single tyres with section widths of—	
(a) less than 375mm	11.0
(b) at least 375mm but less than 450mm	13.3
(c) at least 450mm	14.0
Tandem axle group fitted with single tyres on 1 axle and dual tyres on the other axle on—	
(a) a complying bus	14.0
(b) another motor vehicle	13.0
Tandem axle group fitted with dual tyres on—	
(a) a pig trailer	15.0
(b) another vehicle	16.5
<b>Twinsteer axle groups</b>	
Twinsteer axle group without a load-sharing suspension system	10.0
Twinsteer axle group with a load-sharing suspension system	11.0
<b>Tri-axle groups</b>	
Tri-axle group on a vehicle fitted with—	
(a) single tyres with section widths of less than 375mm on all axles; or	
(b) single tyres with section widths of less than 375mm on some axles and dual tyres on the other axles	15.0

Schedule 1

<b>Description of single axle or axle group</b>	<b>Mass limit (t)</b>
Tri-axle group on a pig trailer fitted with— (a) single tyres with section widths of at least 375mm on all axles; or (b) dual tyres on all axles; or (c) single tyres with section widths of at least 375mm on some axles and dual tyres on the other axles	18.0
Tri-axle group on a vehicle other than a pig trailer fitted with— (a) single tyres with section widths of at least 375mm on all axles; or (b) dual tyres on all axles; or (c) single tyres with section widths of at least 375mm on some axles and dual tyres on the other axles	20.0
<b>Quad-axle groups</b>	
Quad-axle group fitted with single tyres with section widths of less than 3775mm	15.0
Quad-axle group fitted with single tyres with section widths of at least 375mm or dual tyres	20.0

**Table 2—Axle spacing mass limits general table**

<b>Length of axle spacing (m)</b>		<b>Mass limit (t)</b>
<b>at least</b>	<b>less than</b>	
0.0	2.5	15.0
2.5	3.7	23.0
3.7	3.8	23.5
3.8	4.0	24.0
4.0	4.2	24.5
4.2	4.3	25.0

Length of axle spacing (m)		Mass limit (t)
at least	less than	
4.3	4.5	25.5
4.5	4.7	26.0
4.7	4.8	26.5
4.8	5.0	27.0
5.0	5.2	27.5
5.2	5.3	28.0
5.3	5.5	28.5
5.5	5.7	29.0
5.7	5.8	29.5
5.8	6.0	30.0
6.0	6.2	30.5
6.2	6.3	31.0
6.3	6.5	31.5
6.5	6.7	32.0
6.7	6.8	32.5
6.8	7.0	33.0
7.0	7.2	33.5
7.2	7.3	34.0
7.3	7.5	34.5
7.5	7.7	35.0
7.7	7.8	35.5
7.8	8.0	36.0
8.0	8.2	36.5

Schedule 1

Length of axle spacing (m)		Mass limit (t)
at least	less than	
8.2	8.3	37.0
8.3	8.5	37.5
8.5	8.7	38.0
8.7	8.8	38.5
8.8	9.0	39.0
9.0	9.2	39.5
9.2	9.3	40.0
9.3	9.5	40.5
9.5	9.7	41.0
9.7	9.8	41.5
9.8	10.0	42.0
10.0	—	42.5

**Table 3—Axle spacing mass limits B-double table**

Length of axle spacing (m)		Mass limit (t)
at least	less than	
0.0	2.5	15.0
2.5	3.7	23.0
3.7	3.8	23.5
3.8	4.0	24.0
4.0	4.2	24.5
4.2	4.3	25.0
4.3	4.5	25.5
4.5	4.7	26.0

Length of axle spacing (m)		Mass limit (t)
at least	less than	
4.7	4.8	26.5
4.8	5.0	27.0
5.0	5.2	27.5
5.2	5.3	28.0
5.3	5.5	28.5
5.5	5.7	29.0
5.7	5.8	29.5
5.8	6.0	30.0
6.0	6.2	30.5
6.2	6.3	31.0
6.3	6.5	31.5
6.5	6.7	32.0
6.7	6.8	32.5
6.8	7.0	33.0
7.0	7.2	33.5
7.2	7.3	34.0
7.3	7.5	34.5
7.5	7.7	35.0
7.7	7.8	35.5
7.8	8.0	36.0
8.0	8.2	36.5
8.2	8.3	37.0
8.3	8.5	37.5

Heavy Vehicle (Mass, Dimension and Loading) National Regulation

Schedule 1

Length of axle spacing (m)		Mass limit (t)
at least	less than	
8.5	8.7	38.0
8.7	8.8	38.5
8.8	9.0	39.0
9.0	9.2	39.5
9.2	9.3	40.0
9.3	9.5	40.5
9.5	9.7	41.0
9.7	9.8	41.5
9.8	10.0	42.0
10.0	10.2	42.5
10.2	10.3	43.0
10.3	10.5	43.5
10.5	10.7	44.0
10.7	10.8	44.5
10.8	11.0	45.0
11.0	11.2	45.5
11.2	11.3	46.0
11.3	11.7	46.5
11.7	12.0	47.0
12.0	12.3	47.5
12.3	12.7	48.0
12.7	13.0	48.5
13.0	13.3	49.0

Length of axle spacing (m)		Mass limit (t)
at least	less than	
13.3	13.7	49.5
13.7	14.0	50.0
14.0	14.3	50.5
14.3	14.7	51.0
14.7	15.0	51.5
15.0	15.3	52.0
15.3	15.7	52.5
15.7	16.0	53.0
16.0	16.3	53.5
16.3	16.7	54.0
16.7	17.0	54.5
17.0	17.3	55.0
17.3	17.7	55.5
17.7	18.0	56.0
18.0	18.3	56.5
18.3	18.7	57.0
18.7	19.0	57.5
19.0	19.3	58.0
19.3	19.7	58.5
19.7	20.0	59.0
20.0	20.3	59.5
20.3	20.7	60.0
20.7	21.0	60.5

Schedule 1

Length of axle spacing (m)		Mass limit (t)
at least	less than	
21.0	—	62.5

**Table 4—Axle spacing mass limits road train table**

Length of axle spacing (m)		Mass limit (t)
at least	less than	
0.0	2.5	15.0
2.5	3.7	23.0
3.7	3.8	23.5
3.8	4.0	24.0
4.0	4.2	24.5
4.2	4.3	25.0
4.3	4.5	25.5
4.5	4.7	26.0
4.7	4.8	26.5
4.8	5.0	27.0
5.0	5.2	27.5
5.2	5.3	28.0
5.3	5.5	28.5
5.5	5.7	29.0
5.7	5.8	29.5
5.8	6.0	30.0
6.0	6.2	30.5
6.2	6.3	31.0
6.3	6.5	31.5

Length of axle spacing (m)		Mass limit (t)
at least	less than	
6.5	6.7	32.0
6.7	6.8	32.5
6.8	7.0	33.0
7.0	7.2	33.5
7.2	7.3	34.0
7.3	7.5	34.5
7.5	7.7	35.0
7.7	7.8	35.5
7.8	8.0	36.0
8.0	8.2	36.5
8.2	8.3	37.0
8.3	8.5	37.5
8.5	8.7	38.0
8.7	8.8	38.5
8.8	9.0	39.0
9.0	9.2	39.5
9.2	9.3	40.0
9.3	9.5	40.5
9.5	9.7	41.0
9.7	9.8	41.5
9.8	10.0	42.0
10.0	10.2	42.5
10.2	10.3	43.0

Heavy Vehicle (Mass, Dimension and Loading) National Regulation

Schedule 1

Length of axle spacing (m)		Mass limit (t)
at least	less than	
10.3	10.5	43.5
10.5	10.7	44.0
10.7	10.8	44.5
10.8	11.0	45.0
11.0	11.2	45.5
11.2	11.3	46.0
11.3	11.5	46.5
11.5	11.7	47.0
11.7	11.8	47.5
11.8	12.0	48.0
12.0	12.2	48.5
12.2	12.3	49.0
12.3	12.5	49.5
12.5	12.7	50.0
12.7	12.8	50.5
12.8	13.0	51.0
13.0	13.2	51.5
13.2	13.3	52.0
13.3	13.5	52.5
13.5	13.7	53.0
13.7	13.8	53.5
13.8	14.0	54.0
14.0	14.2	54.5

<b>Length of axle spacing (m)</b>		<b>Mass limit (t)</b>
<b>at least</b>	<b>less than</b>	
14.2	14.3	55.0
14.3	14.5	55.5
14.5	14.7	56.0
14.7	14.8	56.5
14.8	15.0	57.0
15.0	15.2	57.5
15.2	15.3	58.0
15.3	15.5	58.5
15.5	15.7	59.0
15.7	15.8	59.5
15.8	16.0	60.0
16.0	16.2	60.5
16.2	16.3	61.0
16.3	16.5	61.5
16.5	16.7	62.0
16.7	16.8	62.5
16.8	17.0	63.0
17.0	17.2	63.5
17.2	17.3	64.0
17.3	17.5	64.5
17.5	17.7	65.0
17.7	17.8	65.5
17.8	18.0	66.0

Heavy Vehicle (Mass, Dimension and Loading) National Regulation

Schedule 1

Length of axle spacing (m)		Mass limit (t)
at least	less than	
18.0	18.2	66.5
18.2	18.3	67.0
18.3	18.5	67.5
18.5	18.7	68.0
18.7	18.8	68.5
18.8	19.0	69.0
19.0	19.2	69.5
19.2	19.3	70.0
19.3	19.5	70.5
19.5	19.7	71.0
19.7	19.8	71.5
19.8	20.0	72.0
20.0	20.2	72.5
20.2	20.3	73.0
20.3	20.5	73.5
20.5	20.7	74.0
20.7	20.8	74.5
20.8	21.0	75.0
21.0	21.2	75.5
21.2	21.3	76.0
21.3	21.5	76.5
21.5	21.7	77.0
21.7	21.8	77.5

Length of axle spacing (m)		Mass limit (t)
at least	less than	
21.8	22.0	78.0
22.0	22.2	78.5
22.2	22.3	79.0
22.3	22.5	79.5
22.5	22.7	80.0
22.7	22.8	80.5
22.8	23.0	81.0
23.0	23.2	81.5
23.2	23.3	82.0
23.3	23.5	82.5
23.5	23.7	83.0
23.7	23.8	83.5
23.8	24.0	84.0
24.0	24.2	84.5
24.2	24.3	85.0
24.3	24.5	85.5
24.5	24.7	86.0
24.7	24.8	86.5
24.8	25.0	87.0
25.0	25.2	87.5
25.2	25.3	88.0
25.3	25.5	88.5
25.5	25.7	89.0

Heavy Vehicle (Mass, Dimension and Loading) National Regulation

Schedule 1

Length of axle spacing (m)		Mass limit (t)
at least	less than	
25.7	25.8	89.5
25.8	26.0	90.0
26.0	26.2	90.5
26.2	26.3	91.0
26.3	26.5	91.5
26.5	26.7	92.0
26.7	26.8	92.5
26.8	27.0	93.0
27.0	27.2	93.5
27.2	27.3	94.0
27.3	27.5	94.5
27.5	27.7	95.0
27.7	27.8	95.5
27.8	28.0	96.0
28.0	28.2	96.5
28.2	28.3	97.0
28.3	28.5	97.5
28.5	28.7	98.0
28.7	28.8	98.5
28.8	29.0	99.0
29.0	29.2	99.5
29.2	29.3	100.0
29.3	29.5	100.5

Length of axle spacing (m)		Mass limit (t)
at least	less than	
29.5	29.7	101.0
29.7	29.8	101.5
29.8	30.0	102.0
30.0	30.2	102.5
30.2	30.3	103.0
30.3	30.5	103.5
30.5	30.7	104.0
30.7	30.8	104.5
30.8	31.0	105.0
31.0	31.2	105.5
31.2	31.3	106.0
31.3	31.5	106.5
31.5	31.7	107.0
31.7	31.8	107.5
31.8	32.0	108.0
32.0	32.2	108.5
32.2	32.3	109.0
32.3	32.5	109.5
32.5	32.7	110.0
32.7	32.8	110.5
32.8	33.0	111.0
33.0	33.2	111.5
33.2	33.3	112.0

Heavy Vehicle (Mass, Dimension and Loading) National Regulation

Schedule 1

Length of axle spacing (m)		Mass limit (t)
at least	less than	
33.3	33.5	112.5
33.5	33.7	113.0
33.7	33.8	113.5
33.8	34.0	114.0
34.0	34.2	114.5
34.2	34.3	115.0
34.3	34.5	115.5
34.5	34.7	116.0
34.7	34.8	116.5
34.8	35.0	117.0
35.0	35.2	117.5
35.2	35.3	118.0
35.3	35.5	118.5
35.5	35.7	119.0
35.7	35.8	119.5
35.8	36.0	120.0
36.0	36.2	120.5
36.2	36.3	121.0
36.3	36.5	121.5
36.5	36.7	122.0
36.7	36.8	122.5
36.8	37.0	123.0
37.0	37.2	123.5

Length of axle spacing (m)		Mass limit (t)
at least	less than	
37.2	37.3	124.0
37.3	37.5	124.5
37.5	37.7	125.0
37.7	37.8	125.5
37.8	38.0	126.0
38.0	38.2	126.5
38.2	38.3	127.0
38.3	38.5	127.5
38.5	38.7	128.0
38.7	38.8	128.5
38.8	39.0	129.0
39.0	39.2	129.5
39.2	39.3	130.0
39.3	39.5	130.5
39.5	39.7	131.0
39.7	39.8	131.5
39.8	40.0	132.0
40.0	40.2	132.5
40.2	40.3	133.0
40.3	40.5	133.5
40.5	40.7	134.0
40.7	40.8	134.5
40.8	41.0	135.0

Heavy Vehicle (Mass, Dimension and Loading) National Regulation

Schedule 1

Length of axle spacing (m)		Mass limit (t)
at least	less than	
41.0	41.2	135.5
41.2	41.3	136.0
41.3	41.5	136.5
41.5	41.7	137.0
41.7	41.8	137.5
41.8	42.0	138.0
42.0	42.2	138.5
42.2	42.3	139.0
42.3	42.5	139.5
42.5	42.7	140.0
42.7	42.8	140.5
42.8	43.0	141.0
43.0	43.2	141.5
43.2	43.3	142.0
43.3	43.5	142.5
43.5	43.7	143.0
43.7	43.8	143.5
43.8	44.0	144.0
44.0	44.2	144.5
44.2	44.3	145.0
44.3	44.5	145.5
44.5	44.7	146.0
44.7	44.8	146.5

Length of axle spacing (m)		Mass limit (t)
at least	less than	
44.8	45.0	147.0
45.0	45.2	147.5
45.2	45.3	148.0
45.3	45.5	148.5
45.5	45.7	149.0
45.7	45.8	149.5
45.8	46.0	150.0
46.0	46.2	150.5
46.2	46.3	151.0
46.3	46.5	151.5
46.5	46.7	152.0
46.7	46.8	152.5
46.8	47.0	153.0
47.0	47.2	153.5
47.2	47.3	154.0
47.3	47.5	154.5
47.5	47.7	155.0
47.7	47.8	155.5
47.8	48.0	156.0
48.0	48.2	156.5
48.2	48.3	157.0
48.3	48.5	157.5
48.5	48.7	158.0

Heavy Vehicle (Mass, Dimension and Loading) National Regulation

Schedule 1

Length of axle spacing (m)		Mass limit (t)
at least	less than	
48.7	48.8	158.5
48.8	49.0	159.0
49.0	49.2	159.5
49.2	49.3	160.0
49.3	49.5	160.5
49.5	49.7	161.0
49.7	49.8	161.5
49.8	50.0	162.0
50.0	50.2	162.5
50.2	50.3	163.0
50.3	50.5	163.5
50.5	50.7	164.0
50.7	50.8	164.5
50.8	51.0	165.0
51.0	51.2	165.5
51.2	51.3	166.0
51.3	51.5	166.5
51.5	51.7	167.0
51.7	51.8	167.5
51.8	52.0	168.0
52.0	52.2	168.5
52.2	52.3	169.0
52.3	52.5	169.5

Length of axle spacing (m)		Mass limit (t)
at least	less than	
52.5	52.7	170.0
52.7	52.8	170.5
52.8	53.0	171.0
53.0	53.2	171.5
53.2	53.3	172.0
53.3	—	172.5

## **Schedule 2      Concessional mass limits**

section 6(3)

### **1      Vehicles to which concessional mass limits apply**

The concessional mass limits apply to a heavy vehicle if—

- (a) the heavy vehicle is not—
  - (i) a class 1 heavy vehicle; or
  - (ii) a bus; or
  - (iii) a combination consisting of a truck and a pig trailer; and
- (b) the operator of the heavy vehicle holds mass management accreditation for the vehicle.

### **2      Concessional mass limits**

- (1) The concessional mass limits apply as an exception to the general mass limits as stated in subsections (2) to (7).
- (2) Subject to subsection (3)(a) and (b), the mass of the heavy vehicle must not be more than the lower of the following—
  - (a) 5% more than the maximum mass permitted for the heavy vehicle under the general mass limits;
  - (b) if the heavy vehicle is fitted with a tandem axle group or tri-axle group—the mass determined by applying section 2 of Schedule 1 with the amount stated for the group in Table 1 of Part 2 of the Schedule changed to the mass exception amount for the group mentioned in subsection (4).
- (3) The mass of the heavy vehicle must not be more than—
  - (a) if the maximum mass permitted for the heavy vehicle under the general mass limits is 55t or less—1t more than the maximum mass permitted for the heavy vehicle under the general mass limits; or

- (b) if the maximum mass permitted for the heavy vehicle under the general mass limits is more than 55t—2t more than the maximum mass permitted for the heavy vehicle under the general mass limits.
- (4) If the heavy vehicle is fitted with a tandem axle group or tri-axle group, the mass of each axle group must not be more than the CML upper mass limit for the axle group (the *mass exception amount*).
- (5) For the purposes of applying the concessional mass limits to a single axle or an axle group, other than an axle group mentioned in the CML upper mass limit Table, the mass limits stated for the axle or axle group in Table 1 of Part 2 of Schedule 1 apply.

*Note—*

In other words, the mass permitted for the axle or axle group is not increased under the concessional mass limits.

- (6) Subsection (7) applies, if, because of the application of subsection (4) to an axle or axle group within a particular axle spacing, the mass permitted for the vehicle is increased by an amount above the general mass limits for the vehicle.
- (7) The mass relating to the axle spacing must not be more than the general mass limits for the axle spacing increased by the same amount.
- (8) In this section—

*CML upper mass limit*, for an axle group with which a heavy vehicle is fitted, means the mass limit stated for the axle group in the following table—

Axle group	Mass limit (t)
<b>Tandem axle group</b>	
Tandem axle group fitted with single tyres on all axles—	
(a) if the section width of the tyres is less than 375mm	11.5

## Schedule 2

<b>Axle group</b>	<b>Mass limit (t)</b>
(b) if the section width of the tyres is 375mm or more but not more than 450mm	13.8
(c) if the section width of the tyres is more than 450mm	14.5
Tandem axle group fitted with single tyres on 1 axle and dual tyres on the other axle or axles	13.5
Tandem axle group fitted with dual tyres on all axles	17
<b>Tri-axle group</b>	
Tri-axle group on a vehicle fitted with—	15.5
(a) single tyres with section widths of less than 375mm on all axles; or	
(b) single tyres with section widths of less than 375mm on some axles and dual tyres on the other axles	
Tri-axle group on a vehicle other than a pig trailer fitted with—	21.0
(a) single tyres with section widths of at least 375mm on all axles; or	
(b) dual tyres on all axles; or	
(c) single tyres with section widths of at least 375mm on some axles and dual tyres on the other axles	

***CML upper mass limit Table*** means the Table to the definition *CML upper mass limit*.

---

## Schedule 4      Quad axle group mass exception limits

section 6(3)

### 1      Quad axle group mass exception limits

- (1) The quad axle group mass exception limits apply to a heavy vehicle fitted with a quad axle group if—
  - (a) all axles in the quad axle group are fitted with dual tyres; and
  - (b) a PBS vehicle approval is in force for the vehicle that permits a mass of up to 27t on the quad axle group; and
  - (c) the vehicle complies with PBS Standards and with the conditions of the PBS vehicle approval.
- (2) The quad axle group mass exception limits apply as an exception to the general mass limits for the quad axle group as stated in subsection (3).
- (3) The mass on the quad axle group must not be more than 27t.

*Note—*

For the mass limit that would otherwise apply, see Schedule 1.

- (4) In this section—

***PBS Standards*** means the Standards and Vehicle Assessment Rules as defined under section 3 of the *Heavy Vehicle (General) National Regulation*.

***PBS vehicle approval*** means a PBS vehicle approval under the *Heavy Vehicle (General) National Regulation*.

## Schedule 5 Higher mass limits

section 6(3)

### 1 Application of higher mass limits to single axle or axle group

- (1) The higher mass limits apply to a single axle or axle group on a heavy vehicle as follows—
  - (a) a single drive axle on a bus;
  - (b) a tandem axle group other than a 6-tyred tandem axle group;
  - (c) a 6-tyred tandem axle group;
  - (d) a tri-axle group.
- (2) The higher mass limits apply if the single drive axle on the bus mentioned in subsection (1)(a) or if an axle group mentioned in subsection (1)(b), (c) or (d)—
  - (a) complies with subsections (3) and (4); and
  - (b) is fitted to a heavy vehicle that complies with subsections (5) and (6).
- (3) The mass permitted for the single axle or axle group under the general mass limits must be at least—
  - (a) for a single drive axle on a bus—9t; or
  - (b) for a tandem axle group other than a 6-tyred tandem axle group—16.5t; or
  - (c) for a 6-tyred tandem axle group—13t; or
  - (d) for a tri-axle group—20t.
- (4) The single axle or axle group must be fitted with a certified road-friendly suspension system.

*Example—*

The Vehicle Standards Bulletin Number 11 mentioned in the definition *certified road-friendly suspension system* in section 3 requires axle groups to have dual tyres.

- 
- (5) The heavy vehicle must be a heavy vehicle that—
- (a) is not a class 1 heavy vehicle; and
  - (b) is not a rigid truck towing a dog trailer or a vehicle fitted with a drive axle group with more than 2 axles (unless it is a B-double or road train); and
  - (c) if the heavy vehicle is fitted with a tri-axle group and is used on a road outside the Northern Territory—is being operated by a person who holds mass management accreditation for the vehicle.
- (6) The higher mass limits apply to the single axle or axle group fitted to a heavy vehicle on all roads—
- (a) within an HML area for the heavy vehicle; or
  - (b) on an HML route for the heavy vehicle.

*Example of how the application of higher mass limits can be decided—*

In deciding whether the higher mass limits may be applied to a tri-axle group, the following questions will need to be answered in the positive—

- is the tri-axle group fitted to a vehicle that complies with subsections (5) and (6)?
- if so, does the tri-axle group qualify for at least 20t under the general mass limits?
- if so, is the axle group fitted with a certified road-friendly suspension system?

## 2 Higher mass limits

- (1) The higher mass limits apply as an exception to the general mass limits as stated in subsections (2) to (4).
- (2) The mass on the single axle or axle group must not be more than the following (the *mass exception amount*)—
  - (a) for a single drive axle on a bus—10t;
  - (b) for a tandem axle group other than a 6-tyred tandem axle group—17t;
  - (c) for a 6-tyred tandem axle group—14t;
  - (d) for a tri-axle group—22.5t.

Schedule 5

---

- (3) The mass of the vehicle must not be more than the mass determined by applying section 2 of Schedule 1 with the amount stated for the single axle or axle group in Table 1 of Part 2 of the Schedule changed to the mass exception amount.
- (4) Subsection (5) applies if, because of the application of subsection (1) to a single axle or axle group within a particular axle spacing, the mass permitted for the vehicle is increased under subsection (3) by an amount above the general mass limits for the vehicle.
- (4) The mass relating to the axle spacing must not be more than the general mass limits for the axle spacing increased by the amount.

---

## Schedule 5A      **One tonne tri-axle mass transfer allowance**

section 6(3)

### **1      One tonne tri-axle mass transfer allowance**

- (1) This section provides for the one tonne tri-axle mass transfer allowance which is a mass exception and is referred to in this Schedule as *the mass exception*.
- (2) The mass exception applies to a tri-axle group on a heavy vehicle if the tri-axle group would otherwise be eligible under the general mass limits to be loaded up to but not above 20t.
- (3) The mass exception applies as an exception to the general mass limits for the tri-axle group as stated in subsection (4).
- (4) The tri-axle group may be loaded up to 21t.
- (5) This section has effect subject to sections 2 to 5.

### **2      Increased mass to be offset as regards the heavy vehicle**

- (1) The application of the mass exception to the heavy vehicle is contingent on—
  - (a) there being a corresponding adjustment in the mass of other axles on the vehicle, but so that the sum of all the axles does not exceed the sum of the general mass limits for all the axles; and
  - (b) compliance with the applicable general mass limits for each of those other axles on the vehicle as so adjusted; and
  - (c) an adjustment by way of decrease for any of those other axles on the vehicle not exceeding 1t; and
  - (d) mass of the vehicle, whether loaded or not, not exceeding the mass determined by applying section 2 of Schedule 1 (but with the amount stated in that section for an axle group or single axle changed in line with any

adjustment permitted by the mass exception as applying to the vehicle).

- (2) A reference in this section to other axles on the vehicle is a reference to all the single axles (if any) and axle groups (if any) on the vehicle other than the tri-axle group to which the mass exception applies.

### **3 Axle spacing**

- (1) This section applies where—
  - (a) the mass of a tri-axle group within a particular axle spacing on the heavy vehicle is permitted by the mass exception to be increased by a particular amount; and
  - (b) the increase would otherwise result in a breach of the mass limits for the axle groups and any single axles within the axle spacing.
- (2) Subject to subsection (3), the mass for the single axles (if any) and axle groups within the axle spacing is permitted to be increased but must not exceed the mass otherwise permitted for the axle spacing increased by the same amount.
- (3) However, the increased mass must be offset by adjusting the masses on other axle groups or single axles, whether within the same axle spacing or different axle spacings.

*Note—*

Requirements about the mass of a heavy vehicle relating to an axle spacing of a heavy vehicle are referred to in section 5 of Schedule 1.

### **4 Adjustments**

An adjustment under this Schedule may be made by way of—

- (a) one or more decreases only; or
- (b) a combination of one or more decreases and one or more increases.

**5 Steer axles and steering axle groups excluded**

This Schedule does not permit the mass limit imposed on a steer axle or twinsteer axle group to be increased or decreased.

## Schedule 6      Dimension requirements

section 37

### Part 1                      Preliminary

#### 1      Meaning of *rear overhang* and *rear overhang line*

- (1) This section defines *rear overhang* and *rear overhang line* for this Regulation.
- (2) The *rear overhang* of a vehicle is the distance between the rear of the vehicle and the rear overhang line of the vehicle.
- (3) For a vehicle with an axle group at the rear comprising only 1 axle, the *rear overhang line* is a line running along the centre-line of the axle.
- (4) For a vehicle with an axle group at the rear comprising 2 axles, 1 of which is fitted with twice the number of tyres as the other, the *rear overhang line* is a line running parallel to the axles that is—
  - (a) closer to the axle carrying the greater number of tyres than it is to the other axle; and
  - (b) located at one-third of the distance between the 2 axles.
- (5) For a vehicle with an axle group at the rear that is not an axle group mentioned in subsection (3) or (4), the *rear overhang line* is a line running parallel to the axles down the centre of the axle group.
- (6) For the purposes of applying subsection (3), (4) or (5) to a vehicle, if an axle group includes at least 1 steerable axle, that axle is to be disregarded unless—
  - (a) the group comprises only 1 axle and that axle is a steerable axle; or
  - (b) all the axles in the group are steerable axles.

*Examples of rear overhang line—*

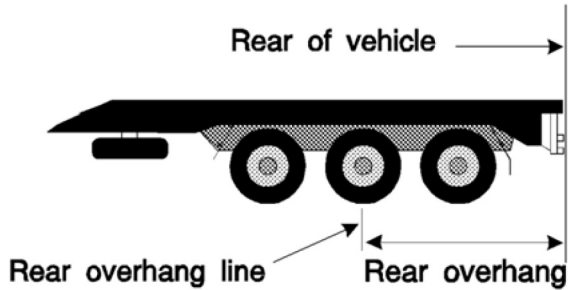

**Rear overhang and rear overhang line — vehicle with tri axle group at rear**

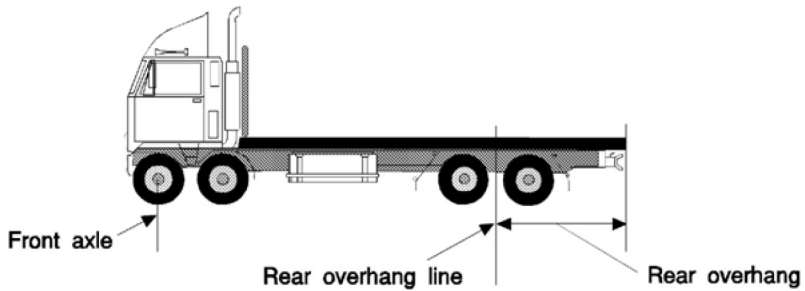

**Rear overhang and rear overhang line — motor vehicle**

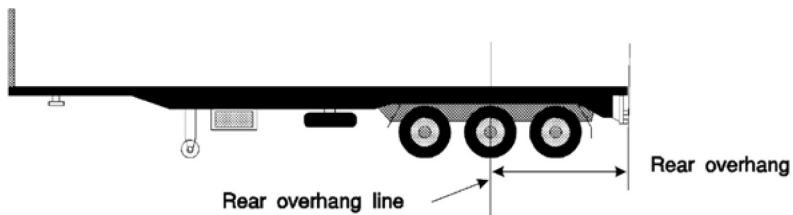

**Rear overhang and rear overhang line — semi-trailer**

## **2 The load is part of a vehicle's dimensions**

In this Schedule, a reference to a vehicle is taken to include a reference to the vehicle together with its load, unless otherwise stated.

# **Part 2 Heavy vehicles**

## **3 Length—general**

- (1) A heavy vehicle must not be longer than—
  - (a) for a combination other than a B-double, road train or a combination with 2 decks for carrying vehicles—19m; or
  - (b) for a B-double—25m; or
  - (c) for a road train—53.5m; or
  - (d) for a combination, other than a road train, designed to carry vehicles on 2 or more partly or completely overlapping decks—25m; or
  - (e) for an articulated bus—18m; or
  - (f) for a bus other than an articulated bus—14.5m; or
  - (g) for another vehicle—12.5m.
- (2) However, subsection (1)(g) applies subject to section 4(9) and (10).
- (3) However, a B-double may be up to 26m long if—
  - (a) the distance from the front articulation point of the most forward semitrailer to the rear of the B-double is not more than 20.6m; and
  - (b) the prime mover in the B-double—
    - (i) is fitted with a front underrun protective device complying with regulation 93 made under the UNECE Agreement or ADR 84—Front Underrun Impact Protection; and

- (ii) for a prime mover manufactured after 31 December 2005—is fitted with a cab complying with regulation 29 made under the UNECE Agreement; and
  - (iii) does not have an area carrying, or built to carry, goods.
- (4) In this section—

***UNECE Agreement*** means the ‘Agreement concerning the adoption of uniform technical prescriptions for wheeled vehicles, equipment and parts which can be fitted and/or be used on wheeled vehicles and the conditions for reciprocal recognition of approvals granted on the basis of these prescriptions’ done at Geneva on 20 March 1958, as amended from time to time.

*Note—*

The agreement and the regulations made under it are available on the United Nations Economic Commission for Europe’s website at <[www.unece.org](http://www.unece.org)>.

#### **4 Length—trailers**

- (1) This section applies to a trailer that is, or forms part of, a heavy vehicle.
- (2) On a semitrailer or dog trailer—
  - (a) the distance from the front articulation point to the rear overhang line must not be more than 9.5m; and
  - (b) the distance from the front articulation point to the rear of the trailer must not be more than 12.3m.
- (3) The part of a semitrailer or anything attached to a semitrailer in front of the trailer’s front articulation point, other than another vehicle, must not protrude beyond the prescribed limit.
- (4) For the purposes of subsection (3), ***prescribed limit*** is an imaginary line created by drawing a semicircle of 1.9m radius from the centre of, and forward of, the front articulation point.

*Example—*

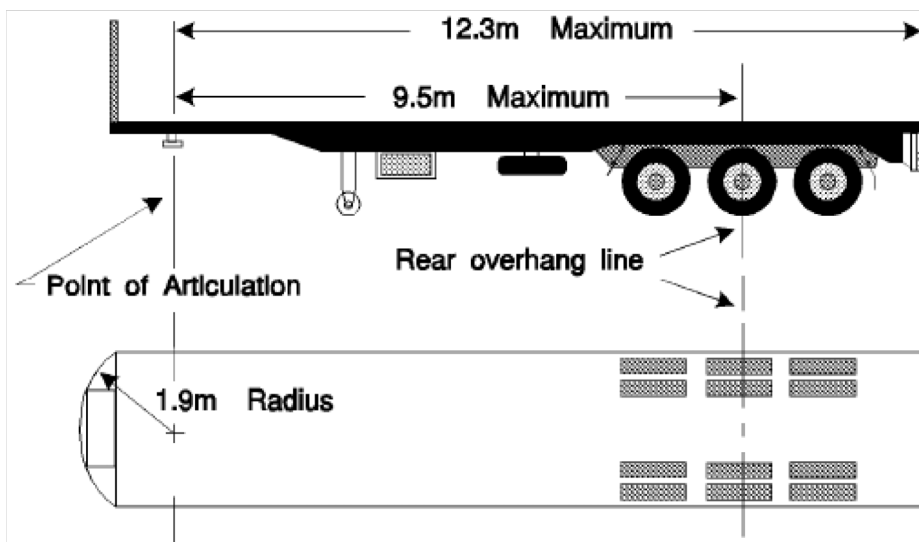

**Measuring distances for subsections (1) to (4)**

- (5) A semitrailer with more than 1 front articulation point must comply with subsections (2) and (3) when measured at one of the points.
- (6) A trailer built to carry cattle, horses, pigs or sheep on 2 or more partly or completely overlapping decks must not have more than 12.5m of its length available to carry cattle, horses, pigs or sheep.
- (7) In a B-double built to carry cattle, horses, pigs or sheep, the 2 semitrailers must not have more than 18.8m of their combined length available to carry cattle, horses, pigs or sheep.
- (8) For subsections (6) and (7), the length available for the carriage of cattle, horses, pigs or sheep on a trailer is measured from the inside of the front wall or door of the trailer to the inside of the rear wall or door of the trailer, with any intervening partitions disregarded.

- (9) Despite subsection (2)(b), the distance from the front articulation point to the rear of a semitrailer may be up to 13.6m if the trailer—
- (a) is designed and constructed for the positive control of temperature through the use of refrigerated equipment; and
  - (b) has a distance from the front articulation point to the rear overhang line of not more than 9.9m; and
  - (c) does not operate in a B-double or road train combination; and
  - (d) otherwise complies dimensionally.

*Example—*

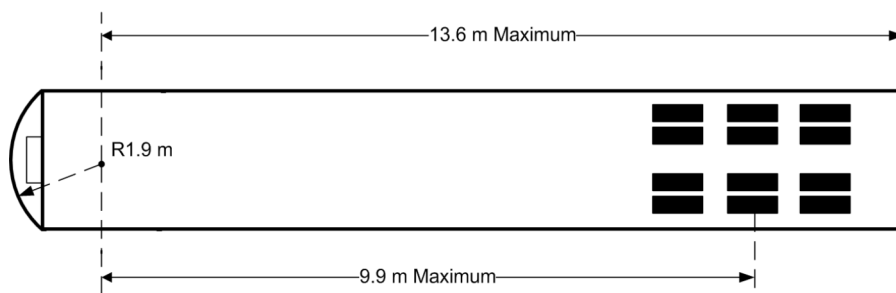

- (10) Despite subsection (2)(b), the distance from the front articulation point to the rear of the semitrailer may be up to 13.2m if the trailer—
- (a) has a distance from the front articulation point to the rear overhang line of not more than 9.5m; and
  - (b) does not operate in a B-double or road train combination; and
  - (c) otherwise complies dimensionally.

*Example—*

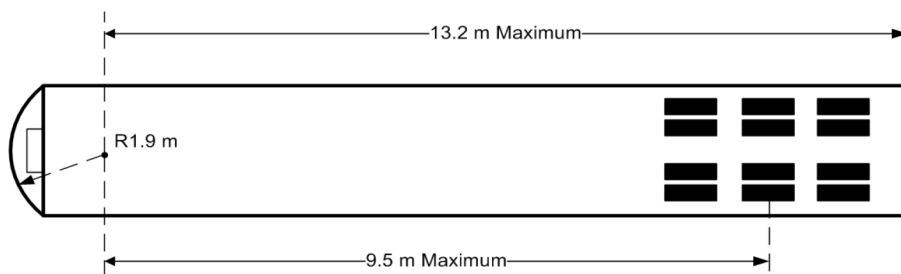

## 5 Length—rear overhang

- (1) The rear overhang of a heavy vehicle must not be more than the lesser of 3.7m and—
  - (a) for a combination that includes a semitrailer or dog trailer—60% of the distance between the trailer’s front articulation point and its rear overhang line; or
  - (b) for a combination that includes another trailer—the distance between the front of the trailer’s body or load carrying area and its rear overhang line; or
  - (c) for another vehicle—60% of the distance between the centre-line of the front axle and the rear overhang line.
- (2) A semitrailer with more than 1 front articulation point must comply with subsection (1)(a) when measured at the same point that is used for measurement for compliance under section 4(4).
- (3) Despite subsection (1), if a vehicle built to carry vehicles (the *primary vehicle*) has at least 2 decks and a vehicle it is carrying overhangs its rear, the rear overhang of the primary vehicle must not be more than 4.9m.

## 6 Length—trailer drawbars

- (1) This section applies to a trailer that is, or forms part of, a heavy vehicle.

- (2) On a dog trailer, the distance between the coupling pivot point on the drawbar and the centre of the front axle group—
- must not be more than 5m; and
  - if the trailer is used in a road train that is longer than 19m—must not be less than 3m.

*Example—*

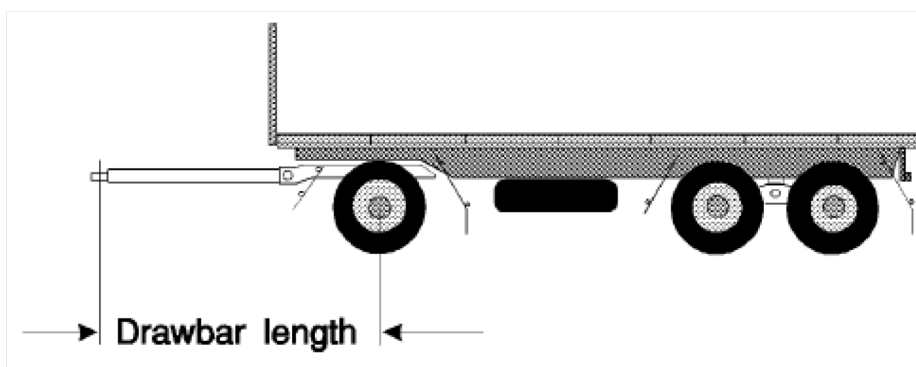

**Measuring distance for subsection (2)**

- (3) On a trailer, other than a semitrailer, with only 1 axle group, the distance between the coupling pivot point on the drawbar and the centre of the axle group must not be more than 8.5m.

## 7 Width

- A heavy vehicle must not be wider than 2.5m.
- When measuring the width of a vehicle for subsection (1), any of the following items that may be fitted to the vehicle are to be disregarded—
  - rear vision mirrors, signalling devices and side-mounted lamps and reflectors;
  - anti-skid devices mounted on wheels, central tyre inflation systems, tyre pressure gauges;
  - permanently fixed webbing assembly-type devices, including, for example, curtain-side devices, if the

maximum distance across the body including any part of the devices does not exceed 2.55m.

## 8 Height

A heavy vehicle must not be higher than—

- (a) for a vehicle built to carry cattle, horses, pigs or sheep—4.6m; or
- (b) for a vehicle built with at least 2 decks for carrying vehicles—4.6m; or

*Note—*

An example is included under section 12(2).

- (c) for a double-decker bus—4.4m; or
- (d) for another vehicle—4.3m.

## 9 Ground clearance

- (1) A heavy vehicle must have a ground clearance of at least—
  - (a) at a point within 1m of an axle—100mm; and
  - (b) at the midpoint between adjacent axles—one-thirtieth of the distance between the centre-line of each axle; and
  - (c) at any other point—the distance that allows the vehicle to pass over a peak in the road if the gradient on either side of the peak is 1:15.

*Example—*

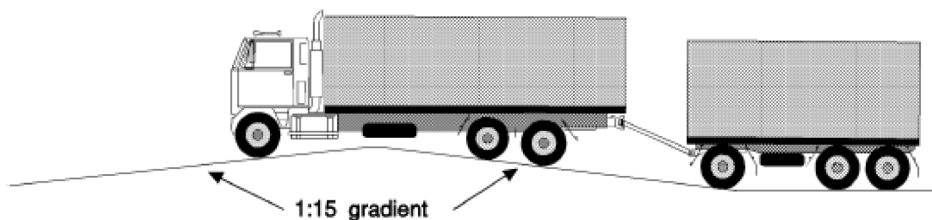

**Measuring ground clearance for paragraph (c)**

(2) In this section—

**ground clearance**, of a vehicle, means the minimum distance between the ground and the vehicle's underside, other than its tyres, wheels, wheel hubs, brake backing plates, flexible mudguards and mudflaps.

## 10 Axle configuration of B-doubles

The axle groups in a heavy combination that is a B-double with 2 tri-axle groups must be positioned so that the following formulae are complied with—

$$X - Y \leq 1$$

$$Y - X \leq 1.3$$

where—

*X* means the distance in metres (measured to the nearest tenth of a metre) between the centre-lines of the last axle of the B-double's prime mover and the first axle of its first semitrailer.

*Y* means the distance in metres (measured to the nearest tenth of a metre) between the centre-lines of the last axle of the B-double's first semitrailer and the first axle of its second semitrailer.

*Example—*

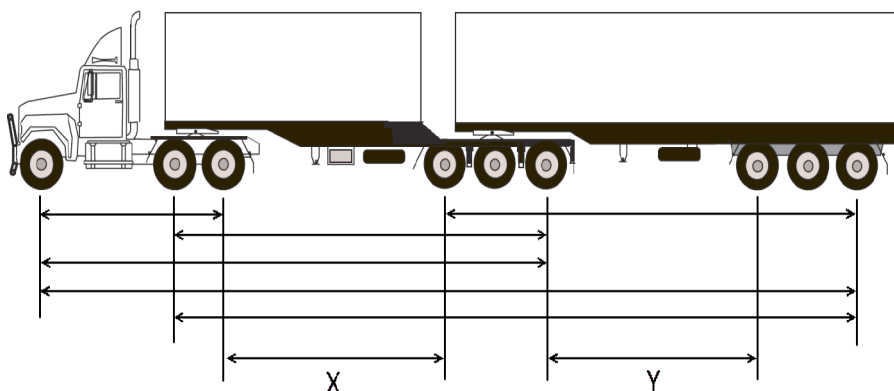

## Part 3 Size and projection of loads

### 11 Definition for pt 3

In this Part—

**load** includes equipment and the pole of a pole-type trailer or jinker.

### 12 In relation to rear of load

- (1) The distance measured at right angles between the rear overhang line of a vehicle and the rear of any load it is carrying must not exceed the rear overhang that the vehicle is permitted under section 5.

*Example—*

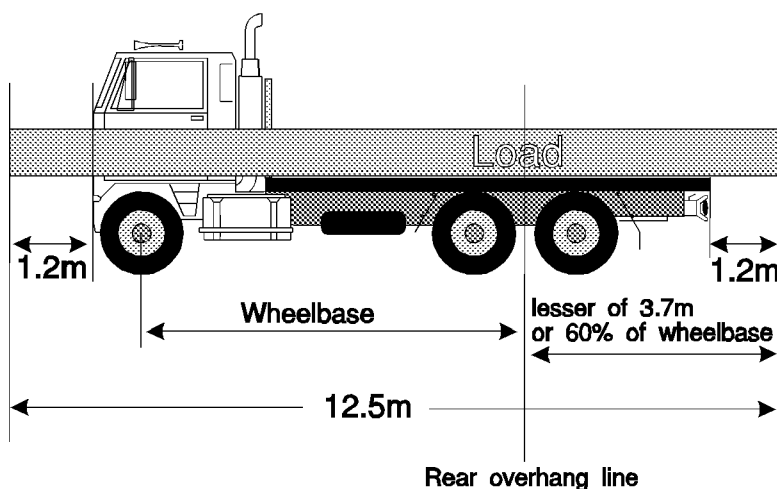

A vehicle complying with—

- the front projection limit under section 13; and
- the rear overhang limit under section 5; and
- the maximum rear projection of a load permitted without a warning signal under section 109 of the Law.

- (2) Despite subsection (1), the distance measured at right angles between the rear overhang line of a trailer carrying vehicles on more than one deck and the rear of the rearmost vehicle on the trailer must not exceed 4.9m.

*Example of maximum permitted dimensions of a loaded car carrier—*

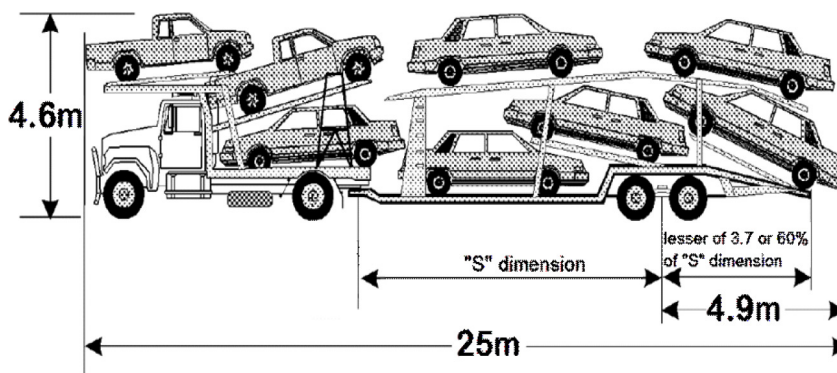

**In the above example, the 'S' dimension is the distance between the trailer's front articulation point and its rear overhang line.**

*Note—*

The combined dimensions of a vehicle and its load must still meet the requirements of section 13 even if the load projects from the vehicle in any direction.

### 13 Front and side projection of load

A load on a heavy vehicle must not project—

- (a) for a heavy vehicle consisting of only a motor vehicle—
  - (i) more than 1.2m in front of the motor vehicle's headlights; or
  - (ii) more than 150mm past the outer extremity of the motor vehicle on either side; or
- (b) for a heavy vehicle consisting of a motor vehicle and 1 or more trailers—
  - (i) more than 1.2m in front of the motor vehicle's headlights; or

- (ii) more than 150mm past the outer extremity on either the motor vehicle or the trailers on either side.

*Example of maximum side projection of load—*

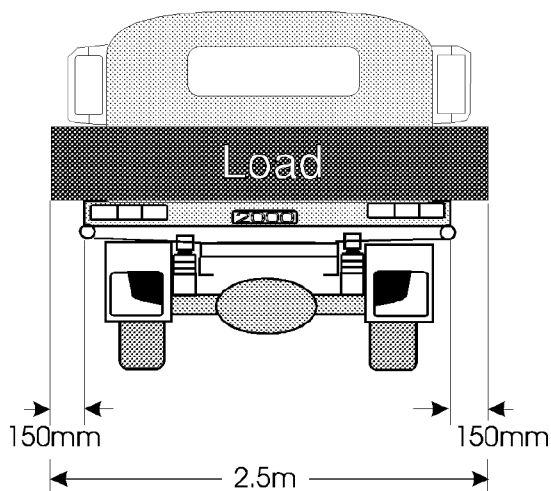

**A vehicle loaded to width limits mentioned in section 7 with maximum side projection of load permitted under this section.**

*Notes—*

- 1 The combined dimensions of a vehicle and its load must still meet the requirements of this section even if the load projects from the vehicle in any direction.
- 2 The example under section 12(1) shows the front projection limit.

---

## **Schedule 7      Loading requirements**

### **section 38**

#### **1      Loading**

- (1) A load on a heavy vehicle must not be placed in a way that makes the vehicle unstable or unsafe.
- (2) A load on a heavy vehicle must be secured so it is unlikely to fall or be dislodged from the vehicle.
- (3) An appropriate method must be used to restrain the load on a heavy vehicle.

*Note—*

See the Load Restraint Guide mentioned in section 115 of the Law and the evidentiary effect under the section of evidence that a load on a heavy vehicle was not restrained in a way that met a performance standard stated in the guide.

## **Schedule 8            Conditions of mass or dimension exemptions applying to class 1 heavy vehicles**

section 39

### **Part 1                    Exemptions granted by Commonwealth Gazette notice**

#### **Division 1              General conditions**

##### **1            Smallest practicable size of unloaded vehicle**

A class 1 heavy vehicle that is not carrying goods must be kept at its smallest practicable dimensions, with any booms fully retracted.

##### **2            Warning signs and flags**

- (1) A class 1 heavy vehicle that, together with its load, is wider than 2.5m or longer than 25m must have—
  - (a) a warning sign attached to the front of the vehicle; and
  - (b) a warning sign attached to the rear of the vehicle or, if a load projects from the rear of the vehicle, to the rear of the load; and
  - (c) 4 brightly coloured red, red and yellow, or yellow flags, each at least 450mm by 450mm, fixed as follows—
    - (i) a flag must be attached at each side of the front of the vehicle or, if a load projects from the front of the vehicle, at each side of the front of the load;

- (ii) a flag must be fixed at each side of the rear of the vehicle or, if a load projects from the rear of the vehicle, at each side of the rear of the load.
- (2) A class 1 heavy vehicle that, together with its load, is not wider than 2.5m, and whose length is more than 22m but not more than 25m, must have a warning sign attached to the rear of the vehicle or, if a load projects from the rear of the vehicle, to the rear of the load.
- (3) Subsections (1) and (2) do not apply to—
  - (a) a heavy vehicle used in connection with the construction of a road and travelling within 1km of the relevant construction site, if a warning light is attached to the vehicle; or
  - (b) a tractor; or
  - (c) a rigid mobile crane less than 3.1m wide.
- (4) In this section—

**construction**, of a road, includes repair or maintenance of the road.

### 3 Warning lights and delineators if load projecting from vehicle

- (1) If a load projects more than 150mm beyond a side of a class 1 heavy vehicle, and the projection is less than 500mm thick from top to bottom—
  - (a) a warning light must be attached to the vehicle; and
  - (b) 2 delineators must be attached to the projection in the way stated in subsection (2) on each side of the vehicle on which the load projects more than 150mm.
- (2) For subsection (1)(b), the delineators must be attached in the following way on each side of the vehicle on which the load projects more than 150mm—
  - (a) at least 1 delineator must be attached to the front of the projection and at least 1 delineator must be attached to the rear of the projection;

- (b) a delineator attached to the front of the projection must be attached so that its reflective surface is facing forward of the vehicle;
  - (c) a delineator attached to the rear of the projection must be attached so that its reflective surface is facing rearward from the vehicle.
- (3) In this section—

***delineator*** means a yellow, rigid piece of material commonly known as a ‘delineator’ that—

- (a) is at least 300mm long and at least 300mm wide; and
- (b) complies with Class 1 or 2 of AS 1906 ‘Retro-reflective Materials and Devices for Road Traffic Control Purposes’.

*Note—*

AS 1906 ‘Retro-reflective Materials and Devices for Road Traffic Control Purposes’ may be purchased from Standards Australia at <[www.standards.org.au](http://www.standards.org.au)>.

#### **4 Warning lights for wide vehicles used in daytime**

If a class 1 heavy vehicle is, together with any load, wider than 3m, a warning light must be attached to the vehicle while it is being used in the daytime.

#### **5 Side and rear markers and warning lights for oversize vehicles used at night**

- (1) If a class 1 heavy vehicle that is an oversize vehicle is being used at night—
- (a) side markers must be displayed, not more than 2m apart, along the total length of each side of the vehicle and any load projecting from the front or rear of the vehicle; and
  - (b) 2 rear markers must be fitted to the rear of any load projecting from the rear of the vehicle, within 400mm of each side of the load and at least 1m but not more than 2.1m above the ground; and

- 
- (c) a warning light must be attached to the vehicle if it, together with any load, is wider than 2.5m or longer than 22m.
- (2) In this section—
- rear markers* means red lights known as ‘rear markers’.
- side markers* means lights showing yellow to the front and red to the rear and known as ‘side markers’.

## 6 Headlights

- (1) This section applies to a class 1 heavy vehicle that is an oversize vehicle, or the towing vehicle of a class 1 heavy vehicle that is an oversize vehicle, that is required to have headlights under the *Heavy Vehicle (Vehicle Standards) National Regulation*.
- (2) The class 1 heavy vehicle, or the towing vehicle, must have its low-beam headlights on while it is being used in the daytime.
- (3) In this section—
- low-beam*, for a headlight fitted to a heavy vehicle, has the meaning it has for the purposes of the *Heavy Vehicle (Vehicle Standards) National Regulation*.

## 7 Travel restrictions at night

A class 1 heavy vehicle that, together with any load, is wider than 3.1m or longer than 22m, must not, while being used at night—

- (a) travel outside an urban area; or
- (b) travel in an urban area without being accompanied by a pilot vehicle.

## 8 No travelling if low visibility

- (1) A class 1 heavy vehicle must not begin to travel if, due to circumstances such as fog, heavy rain, smoke, dust or insect plague—

- (a) visibility is less than 250m in the daytime; or
  - (b) the headlights of a vehicle approaching within 250m could not be seen at night.
- (2) If a class 1 heavy vehicle is already travelling when visibility is reduced to the level mentioned in subsection (1), the vehicle's driver must drive the vehicle into the nearest safe parking area and wait until visibility improves beyond that level before continuing to travel.
- (3) In this section—
- safe parking area*, for a class 1 heavy vehicle, means an area at which vehicles of that kind may be parked lawfully and safely.

## 9 Minimum following distance

- (1) The person driving a class 1 heavy vehicle that is an oversize vehicle must drive at least 200m behind another oversize vehicle travelling in front of it, unless the person is—
- (a) driving on—
    - (i) a multi-lane road; or
    - (ii) a length of road in a built-up area; or
  - (b) overtaking.
- (2) In this section—
- built-up area* has the meaning it has for the purposes of the Road Rules.
- multi-lane road* has the meaning it has for the purposes of the Road Rules.

## 10 Allowing overtaking

- (1) This section applies if a class 1 heavy vehicle is being driven on a road, or a part of a road, that does not have a separate lane for overtaking vehicles.

- 
- (2) The person driving the class 1 heavy vehicle must, at regular intervals and to the extent reasonably practicable, move the vehicle off the road to allow other vehicles to overtake it.

## 11 Assessing routes

- (1) Before a class 1 heavy vehicle is driven along any route, its driver and operator must be satisfied that the route has been assessed and that the vehicle can be driven along it without contravening subsection (2).
- (2) A class 1 heavy vehicle must not be driven along a route if to do so would be likely to cause—
  - (a) disruption to telecommunication, electricity, rail, gas, water or sewage services (*relevant services*); or
  - (b) damage to a road (including a bridge), structure, rail crossing or tree (*relevant property*).
- (3) Subsection (2) does not apply if the entity responsible for the relevant services or relevant property has given permission for the vehicle to travel along the route, and the vehicle is driven in accordance with the permission.

## Division 2 Load-carrying vehicles

### 12 Application of Div 2

- (1) This Division applies only to a class 1 heavy vehicle that is a load-carrying vehicle.
- (2) A reference in this Division to a load-carrying vehicle is taken to be a reference to a load-carrying vehicle that is a class 1 heavy vehicle.

### 13 Carrying goods in addition to a large indivisible item

- (1) A load-carrying vehicle must not carry more than 1 large indivisible item unless—

- (a) the vehicle together with its load complies with the general mass limits; and
  - (b) the vehicle carrying more than 1 large indivisible item does not cause the vehicle together with its load to exceed a prescribed dimension requirement that would not be exceeded if the vehicle carried only 1 of the large indivisible items.
- (2) A load-carrying vehicle carrying 1 or more large indivisible items must not carry any other goods unless—
- (a) the vehicle together with its load complies with the general mass limits; and
  - (b) the other goods are contained within the limits set by the prescribed dimension requirements.
- (3) Despite subsection (2), a load-carrying vehicle carrying a special purpose vehicle or agricultural vehicle may also carry equipment, tools, substances or detached parts to be used in conjunction with the vehicle being carried.
- (4) In this section—
- large indivisible item* has the meaning it has under section 116(4) of the Law.

#### **14 Towing a low loader dolly with an unladen low loader**

An unladen low loader must not be towed in a combination with a low loader dolly unless—

- (a) the combination is 2.5m wide or less; and
- (b) it would be unreasonable to require the dolly to be loaded onto the low loader because of the short distance to be travelled, or special difficulties in loading or unloading the dolly due to the nature of the location where the loading or unloading is to take place.

---

## Division 3                      Special purpose vehicles

### 15      Application of Div 3

- (1) This Division applies only to a class 1 heavy vehicle that is a special purpose vehicle.
- (2) A reference in this Division to a special purpose vehicle is taken to be a reference to a special purpose vehicle that is a class 1 heavy vehicle.

### 16      Side lights for travel at night with long front projections

- (1) When travelling at night, a special purpose vehicle with a projection extending more than 1.2m in front of the vehicle must have a yellow light fixed on each side of the projection.
- (2) The light must be—
  - (a) fixed as far forward as possible, and shielded from the driver's view; and
  - (b) visible to any traffic approaching the vehicle from its front; and
  - (c) visible to any traffic approaching the vehicle from the side on which it is fixed.

### 17      Rear marking plates and warning patterns

- (1) A rear marking plate must be fitted to the rearmost part of the body of a special purpose vehicle.
- (2) A warning pattern must be displayed on the left and right sides of any rigid projection extending more than 1.2m in front of the body of a special purpose vehicle.
- (3) In this section—

*rear marking plate* means a plate that—

  - (a) warns other road users that the vehicle to which the plate is attached is an oversize vehicle; and

- (b) complies with ‘Standards Bulletin VSB12—Rear Marking Plates’ published by the Vehicle Safety Branch of the Western Australian Department of Planning and Infrastructure.

*Note—*

A copy of the bulletin may be obtained from the website of the Commonwealth Department of Infrastructure and Transport at <[www.infrastructure.gov.au](http://www.infrastructure.gov.au)>.

## **18 Prohibition on towing other vehicles**

A special purpose vehicle must not tow a vehicle.

## **Division 4 Agricultural vehicles**

### **19 Application of Div 4**

- (1) This Division applies only to a class 1 heavy vehicle that is an agricultural vehicle or agricultural combination.
- (2) A reference in this Division to an agricultural vehicle or agricultural combination is taken to be a reference to an agricultural vehicle or agricultural combination that is a class 1 heavy vehicle.

### **20 Warning devices for agricultural vehicles or combinations**

- (1) An agricultural vehicle or agricultural combination wider than 2.5m, or an agricultural combination longer than 22m, must have a warning light attached to its highest practicable point when it is on a major road.
- (2) A warning sign must be attached to the rear of an agricultural implement being towed by a tractor.
- (3) A warning pattern must be displayed at the sides of the rear of any auger, conveyor, or the reaping implement of a combine harvester.

- 
- (4) Any part of an axle extending more than 150mm from the outside wall of a tractor's tyre must be painted fluorescent yellow or have yellow fluorescent or other high-visibility material wrapped around it.
- (5) In this section—
- combine harvester* means an agricultural vehicle that simultaneously performs operations of reaping, threshing and winnowing grain crops.

## 21 Pilot vehicle requirements for agricultural vehicles or combinations

- (1) An agricultural vehicle or agricultural combination wider than 3.7m but not wider than 4.5m must be accompanied by at least 1 pilot vehicle if—
- (a) any part of the terrain in which it is being used limits a clear view of approaching traffic to less than 500m; or
  - (b) it is being used on a major road.
- (2) An agricultural vehicle or agricultural combination wider than 4.5m—
- (a) must be accompanied by at least 1 pilot vehicle unless paragraph (b) applies; and
  - (b) must be accompanied by at least 2 pilot vehicles if—
    - (i) any part of the terrain in which it is being used limits a clear view of approaching traffic to less than 500m; or
    - (ii) it is being used on a major road.
- (3) Despite subsections (1) and (2), an agricultural vehicle or agricultural combination does not have to be accompanied by a pilot vehicle if it is travelling less than 500m.

## 22 Agricultural vehicles or combinations not to be used on freeway

- (1) An agricultural vehicle or agricultural combination must not be used on a freeway.

(2) In this section—

*freeway* has the meaning it has for the purposes of the Road Rules.

**23 Agricultural implements not to carry goods or passengers**

An agricultural implement must not carry goods or passengers.

**24 Speed limits for agricultural implements without brakes**

An agricultural implement without brakes must not be towed by a vehicle at a speed greater than the lesser of the following—

- (a) 20km/hr less than the speed limit applying to the vehicle under the Road Rules;
- (b) 50km/hr.

**Division 5 Pilot and escort vehicles**

**25 Application of Div 5**

(1) This Division—

- (a) applies if, under a condition in Divisions 1 to 4, a class 1 heavy vehicle must be accompanied by a pilot vehicle or escort vehicle; and
- (b) prescribes requirements about the pilot vehicle or escort vehicle or its operation.

(2) A reference in this Division to a pilot vehicle or escort vehicle is taken to be a reference to a pilot vehicle or escort vehicle accompanying a class 1 heavy vehicle under a condition in Divisions 1 to 4.

---

**26 Requirements for a pilot vehicle**

- (1) A pilot vehicle must have at least 4 wheels and a GVM of—
  - (a) no more than 4.5t unless paragraph (b) applies; or
  - (b) if the pilot vehicle is the rear pilot vehicle of 2 pilot vehicles that are required to accompany a class 1 heavy vehicle—no more than 6.5t.
- (2) A pilot vehicle must have a warning sign attached to its roof.
- (3) A pilot vehicle must only have a warning light attached—
  - (a) above or below the warning sign; or
  - (b) at each side of the warning sign.

**27 Requirements for an escort vehicle**

- (1) An escort vehicle must have—
  - (a) at least 4 wheels; and
  - (b) a GVM of 4.5t or less; and
  - (c) 1 or 2 warning lights on its roof.
- (2) If the vehicle is a police vehicle or transport enforcement vehicle, the warning light, instead of flashing yellow, may flash a colour that a light on the roof of an exempt vehicle is required or permitted to be under section 79 of Schedule 2 of the *Heavy Vehicle (Vehicle Standards) National Regulation*.
- (3) This section does not apply to an escort vehicle that is a motor cycle driven by a police officer in the course of the officer's duty.

**28 Headlights on a pilot or escort vehicle**

- (1) The low-beam headlights on a pilot vehicle or escort vehicle must be switched on when it is accompanying a class 1 heavy vehicle during the daytime.
- (2) In this section—

*low-beam*, for a headlight fitted to a pilot vehicle or escort vehicle, has the meaning it has—

- (a) if the pilot vehicle or escort vehicle is a heavy vehicle—in section 4 of the *Heavy Vehicle (Vehicle Standards) National Regulation*; or
- (b) otherwise—for the purposes of the provisions of the light vehicle standards prescribing requirements about the headlights of the vehicle.

## **29 Restriction on what a pilot or escort vehicle may carry**

A pilot vehicle or escort vehicle must not tow a trailer or carry goods, but it may carry equipment or substances for use in connection with the class 1 heavy vehicle it is accompanying or for restraining a load on that heavy vehicle.

## **30 Where a pilot vehicle must be driven**

- (1) If 1 pilot vehicle accompanies a class 1 heavy vehicle, the pilot vehicle must travel—
  - (a) behind the heavy vehicle if they are on a divided road; or
  - (b) in front of the heavy vehicle if they are on a road that is not divided.
- (2) If 2 pilot vehicles accompany a class 1 heavy vehicle, 1 pilot vehicle must travel in front of the heavy vehicle, and the other behind it.
- (3) A pilot vehicle must travel far enough away from the class 1 heavy vehicle it is accompanying to give adequate warning to other road users of the presence of the heavy vehicle, taking into account traffic speed, weather, visibility and other driving conditions.

## **31 Communication between drivers**

- (1) A class 1 heavy vehicle and any accompanying pilot vehicle or escort vehicle must have a device that allows the drivers to communicate effectively with each other.
- (2) Subsection (1) does not apply—
  - (a) if the class 1 heavy vehicle is—

- (i) an agricultural machine; or
  - (ii) a heavy combination that includes an agricultural machine; or
- (b) in relation to a class 1 heavy vehicle accompanied by an escort vehicle that is a police vehicle.

## **Part 2 Exemptions granted by issuing a permit**

### **32 Application of Pt 2**

- (1) This Part applies only to a class 1 heavy vehicle that is a special purpose vehicle.
- (2) A reference in this Part to a special purpose vehicle is taken to be a reference to a special purpose vehicle that is a class 1 heavy vehicle.

### **33 Restriction on towing other vehicles**

- (1) A special purpose vehicle must not tow a vehicle.
- (2) Subsection (1) does not apply to a crane towing a single trailer if—
  - (a) the crane has no more than 5 axles; and
  - (b) the load on the trailer includes only equipment required for the normal operation of the crane; and
  - (c) the swept path of the combination consisting of the crane and trailer turning a corner is not greater than what the swept path of the crane alone turning a corner would be.

## **Part 3**                      **All mass or dimension exemptions**

### **Division 1**                **Warning lights**

#### **34**      **Application of Div 1**

(1) This Division—

- (a) applies if a class 1 heavy vehicle, or a pilot vehicle or escort vehicle accompanying a class 1 heavy vehicle, must have 1 or more warning lights on it under a condition of the mass or dimension exemption under which the class 1 heavy vehicle is being used; and

*Note—*

Part 1 prescribes conditions about warning lights for class 1 heavy vehicles, or pilot vehicles or escort vehicles accompanying class 1 heavy vehicles, being used under a mass or dimension exemption granted by Commonwealth Gazette notice.

- (b) prescribes requirements about the warning lights.
- (2) A reference in this Division to a pilot vehicle or escort vehicle is taken to be a reference to a pilot vehicle or escort vehicle accompanying a class 1 heavy vehicle.

#### **35**      **Characteristics of warning light**

- (1) A warning light attached to a class 1 heavy vehicle, pilot vehicle or escort vehicle, when switched on, must—
- (a) emit a yellow coloured light of rotating and flashing effect; and
  - (b) flash between 120 and 200 times a minute; and
  - (c) have a power of at least—
    - (i) if LED technology is used— 25W; or
    - (ii) if another technology is used—55W; and
  - (d) not be a strobe light.

- 
- (2) However, subsection (1) does not apply to a warning light that—
- (a) is attached to an escort vehicle that is a police vehicle or transport enforcement vehicle; and
  - (b) complies with the requirements of the light vehicle standards for lights attached to a vehicle of that kind.

### **36 Visibility of warning lights**

- (1) A warning light attached to a class 1 heavy vehicle, pilot vehicle or escort vehicle must be—
- (a) clearly visible at a distance of 500m in all directions; or
  - (b) supplemented by 1 or more additional warning lights so that the light emanating from at least 1 of them is clearly visible at a distance of 500m in any direction.
- (2) However, for a pilot vehicle travelling in front of a class 1 heavy vehicle, a filter may be placed behind the warning light attached to the pilot vehicle to reduce the intensity of the light directed to the driver of the heavy vehicle.

### **37 Switch for warning lights to be within easy reach**

The switch for a warning light attached to a class 1 heavy vehicle, pilot vehicle or escort vehicle must be within easy reach of the driver in the normal driving position in the vehicle.

### **38 Warning lights to be on if required, and off if not**

- (1) A warning light attached to a class 1 heavy vehicle must only be switched on when the heavy vehicle is travelling, or is stationary in a position that is likely to cause danger to other road users.
- (2) A warning light attached to a pilot vehicle or escort vehicle must be switched on when the vehicle is travelling and accompanying a class 1 heavy vehicle.

## **Division 2            Warning signs**

### **Subdivision 1        Preliminary**

#### **39        Application of Div 2**

(1) This Division—

- (a) applies if a class 1 heavy vehicle, or a pilot vehicle accompanying a class 1 heavy vehicle, must have 1 or more warning signs on it under a condition of the mass or dimension exemption under which the class 1 heavy vehicle is being used; and

*Note—*

Part 1 prescribes conditions about warning signs for class 1 heavy vehicles, or pilot vehicles accompanying class 1 heavy vehicles, being used under a mass or dimension exemption granted by Commonwealth Gazette notice.

- (b) prescribes requirements about the warning signs.

(2) A reference in this Division to a pilot vehicle is taken to be a reference to a pilot vehicle accompanying a class 1 heavy vehicle.

### **Subdivision 2        Class 1 heavy vehicles and pilot vehicles**

#### **40        Application of Sdiv 2**

This Subdivision applies to both warning signs required to be on a class 1 heavy vehicle and warning signs required to be on a pilot vehicle accompanying a class 1 heavy vehicle.

#### **41        Face of warning sign**

The face of a warning sign on a class 1 heavy vehicle or pilot vehicle must have—

- (a) a yellow surface complying with class 1 or 2 of AS 1906 ‘Retro-reflective Materials and Devices for Road Traffic Control Purposes’; and

*Note—*

AS 1906 ‘Retro-reflective Materials and Devices for Road Traffic Control Purposes’ may be purchased from Standards Australia at <[www.standards.org.au](http://www.standards.org.au)>.

- (b) a black border that is at least 20mm wide and, unless the sign has been made with a box edge, whose outermost edge is at least 10mm in from the edge of the sign; and
- (c) its manufacturer’s name or trademark, and the brand and class of material used for the warning sign’s surface, permanently marked in letters at least 3mm but no more than 10mm high—
- (i) for a class 1 heavy vehicle—on any visible part of the sign; or
- (ii) for a pilot vehicle—on any visible part of the sign other than a bottom corner.

## **42 Material of warning sign**

- (1) A warning sign on a class 1 heavy vehicle or pilot vehicle must be made of stiff, flat, weatherproof material.

*Examples of material that may comply with subsection (1)—*

- zincalume that is at least 0.8mm thick
- aluminium that is at least 1.6mm thick

- (2) However, a warning sign on a class 1 heavy vehicle or pilot vehicle may be made of flexible, weatherproof material if the sign is—
- (a) held taut; and
- (b) clearly visible; and
- (c) unlikely to become dislocated, furl or otherwise become difficult to read by other road users.

### **43 Keeping signs clean**

A warning sign on a class 1 heavy vehicle or pilot vehicle must be kept clean enough so that it can be easily read by other road users.

## **Subdivision 3 Class 1 heavy vehicles only**

### **44 Application of Sdiv 3**

This Subdivision applies only to warning signs required to be on a class 1 heavy vehicle.

### **45 Size of warning sign**

- (1) A warning sign on a class 1 heavy vehicle must be at least 1200mm long and at least 450mm high.
- (2) The length of a warning sign on a class 1 heavy vehicle may be split into 2 parts, in which case the combined length of its parts must be at least 1200mm.

### **46 Face of warning sign**

- (1) A warning sign on a class 1 heavy vehicle must show the word 'OVERSIZE', in black capital letters, and in typeface Series C(N) complying with AS 1744 'Forms of Letters and Numerals for Road Signs'.

*Note—*

AS 1744 'Forms of Letters and Numerals for Road Signs' may be purchased from Standards Australia at <[www.standards.org.au](http://www.standards.org.au)>.

- (2) The letters must be—
  - (a) at least 200mm high; and
  - (b) at least 125mm from the top and bottom of the warning sign.
- (3) If the length of the warning sign is split into 2 parts—

- (a) the part fitted on the left must show the word 'OVER' and the part fitted on the right must show the word 'SIZE'; and
- (b) there must be no border between the 2 parts, despite section 41(b).

*Example of a warning sign for an oversize vehicle or combination—*

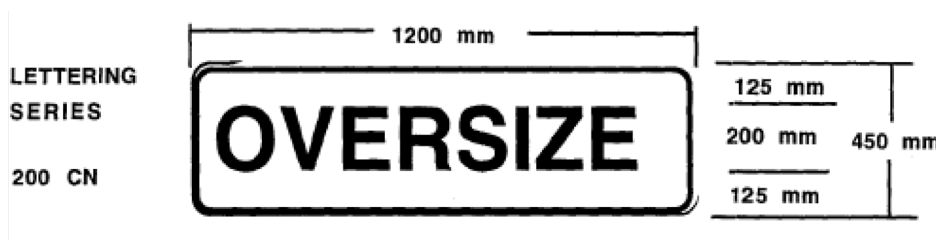

#### 47 Fitting warning sign

- (1) A warning sign on a class 1 heavy vehicle must be fitted horizontally.
- (2) The lower edge of the warning sign must be—
  - (a) above the bottom of the bumper bar; or
  - (b) if there is no bumper bar—at least 500mm above ground level.
- (3) If the length of the warning sign is split into 2 parts, each part must be fitted at the same height as the other.

### Subdivision 4 Pilot vehicles only

#### 48 Application of Sdiv 4

This Subdivision applies only to warning signs required to be on a pilot vehicle accompanying a class 1 heavy vehicle.

**49 Size and shape of warning sign**

- (1) A warning sign on a pilot vehicle must be at least 1200mm long and at least 600mm high.
- (2) The warning sign may have bottom corner cut-outs not more than 150mm wide and not more than 100mm high if they are needed for fitting the warning sign to the pilot vehicle.

**50 Faces of warning sign**

- (1) Both faces of a warning sign on a pilot vehicle must show—
  - (a) the word ‘OVERSIZE’, in black capital letters at least 200mm high, and complying with AS 1744 ‘Forms of Letters and Numerals for Road Signs’, in typeface Series C(N); and
  - (b) the words ‘LOAD AHEAD’, in black capital letters at least 100mm high, and complying with AS 1744 ‘Forms of Letters and Numerals for Road Signs’, in typeface Series D(N).

*Note—*

AS 1744 ‘Forms of Letters and Numerals for Road Signs’ may be purchased from Standards Australia at <[www.standards.org.au](http://www.standards.org.au)>.

- (2) The bottom of the letters of the word ‘OVERSIZE’ must be at least 300mm from the bottom of the warning sign.
- (3) The bottom of the letters of the words ‘LOAD AHEAD’ must be at least 100mm from the bottom of the warning sign.

*Example of a warning sign for a pilot vehicle—*



**51 Fitting warning sign**

A warning sign on a pilot vehicle must not lean back so that there is more than 200mm measured horizontally from the top of the sign to a vertical line running through the bottom of the sign.

*Example—*

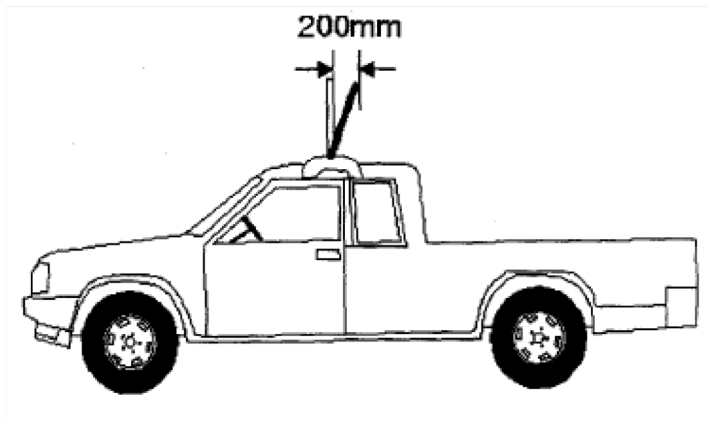

**maximum slant of warning sign**

## **Schedule 9      Imposition of road conditions in relation to a class 2 heavy vehicle**

section 44

<b>Kind of road condition</b>	<b>Circumstances for imposing the kind of road condition</b>
requirements about the types of loads that a heavy vehicle may carry	if an area or route is not suitable for access by all or stated categories of class 2 heavy vehicles but access is needed for vehicles that service an industry local to the area or route to carry specified loads, such as grain or sugar cane
restrictions on turning in a given direction	if the road alignment or geometry is not conducive to all or stated categories of class 2 heavy vehicles making a turn in a given direction safely or without undue risk to road infrastructure

Kind of road condition	Circumstances for imposing the kind of road condition
<p>requirements about the permissible mass of a heavy vehicle (including its equipment) or a component or load of a heavy vehicle, including for specified axles or axle groups or axle spacings, including requirements about maximum or minimum mass limits or for the vehicle to be unladen or for the stated category of class 2 heavy vehicle to not be able to be used at higher mass limits on a stated area or route</p>	<p>if it is necessary to protect vulnerable road infrastructure from excessive rates of wear and damage caused by excessive mass</p> <p>if it is necessary to protect vulnerable road infrastructure from mass that is insufficient to ensure that drive axles maintain traction with the road pavement</p> <p>if specifying vehicle load distribution is necessary to protect road infrastructure from excessive rates of wear or damage by ensuring adequate drive axle traction on steep inclines</p>

Kind of road condition	Circumstances for imposing the kind of road condition
<p>conditions about which lane or lanes a heavy vehicle may or may not be used on</p>	<p>if there is a demonstrated and significant elevated risk of wear or damage to road infrastructure relative to travelling in another lane or lanes in a specified area or route</p> <p>if a significant benefit to road infrastructure will result from imposing the condition, such as travelling through roundabouts or helping to prevent collision with roadside furniture, poles and signs</p> <p>if a reduction in traffic congestion will result from imposing the condition</p> <p>if a specified section of road has been assessed as unsafe for all or stated categories of class 2 heavy vehicles to overtake other vehicles and it is necessary to restrict such vehicles to operating in specified lanes</p>
<p>requirements about minimum spacing between all or stated categories of class 2 heavy vehicles when travelling on a specified area or route</p>	<p>if there is a demonstrated and significant elevated risk of wear or damage to road infrastructure arising from all or stated categories of class 2 heavy vehicles travelling in close proximity to other class 2 heavy vehicles</p> <p>if road conditions make attempts by other motorists to overtake all or stated categories of class 2 heavy vehicles more likely (such as on inclines where the heavy vehicles may be unable to keep pace with general traffic), but where travelling in close proximity to other heavy vehicles would make such overtaking attempts more difficult or less safe</p>

Kind of road condition	Circumstances for imposing the kind of road condition
restrictions on proceeding past a nominated point on a road until the driver has ascertained that it is safe to do so	if there are sections of road with limited forward visibility and insufficient width for more than one vehicle to pass safely, including narrow stretches of road and single lane bridges
conditions about the maximum speed at which all or stated categories of class 2 heavy vehicles may be driven in or on a stated area, road or route, being lower than the speed limit applying to other traffic in that area	<p>if there are sections of road in an area that is built up or within town limits with high pedestrian or vehicle traffic and the use of all or stated categories of class 2 heavy vehicles at the speed limit applying to other traffic in that area is a greater safety risk than for other vehicle categories</p> <p>if it is necessary to minimise wear and damage to unsealed road surfaces when wet or dusty or in other poor weather conditions</p> <p>if there is an elevated risk of loss of vehicle control, including from steep or winding descents</p> <p>if there is an elevated risk to road safety generally</p> <p>if a route is a school bus route</p>

Schedule 9

Kind of road condition	Circumstances for imposing the kind of road condition
<p>requirements to yield to other vehicles, being in addition to requirements under the Road Rules</p>	<p>if it is necessary to manage traffic flow to minimise traffic congestion, such as in ferry boarding and unloading areas where priority loading or parking is required</p> <p>if it is necessary to manage traffic flow on narrow roads to allow another vehicle to pass or at intersections where all or stated categories of class 2 heavy vehicles may need to use opposing traffic lanes to negotiate a corner</p> <p>if road infrastructure or traffic conditions make overtaking all or stated categories of class 2 heavy vehicles unsafe or where it would contribute to increased traffic congestion, such as where the heavy vehicle was unable to keep pace with general traffic (for example, on steep inclines)</p>
<p>restrictions on travelling during stated periods or stated weather conditions</p>	<p>during the wet season when roads in an area or route are in such condition that it would be unsafe for all or stated categories of class 2 heavy vehicles to be used on those roads or where such use would contribute to unacceptable damage to road infrastructure</p> <p>if there are specified weather conditions and it would be unsafe for all or stated categories of class 2 heavy vehicles to be used on roads in an area or route or where such use would contribute to unacceptable damage to road infrastructure</p>

## Schedule 10 Reviewable decisions

section 45

### Part 1 Decisions of the Regulator

Section under which decision made	Description of decision
section 20	decision of Regulator not to issue an HML permit other than because a relevant road manager for the permit did not consent to the issue
section 20	decision of Regulator to issue an HML permit for a period less than the period of not more than 3 years sought by the applicant
section 24	decision of Regulator to impose on an HML permit a condition not sought by the applicant and not a road condition required by a relevant road manager for the permit
section 29	decision of Regulator to amend or cancel an HML permit
section 35	decision of Regulator not to give a replacement permit for an HML permit

## **Part 2**                      **Decisions of relevant road managers**

<b>Section under which decision made</b>	<b>Description of decision</b>
section 23	decision of a relevant road manager for an HML permit, that is a public authority, not to consent to the issue of the permit
section 23	decision of a relevant road manager for an HML permit, that is a public authority, to consent to the issue of the permit on the condition that a road condition be imposed on the permit
section 31	decision of relevant road manager for an HML permit, that is a public authority, to request the amendment or cancellation of an HML permit

## 1 Index to endnotes

- 2 Key
- 3 Table of reprints
- 4 List of legislation
- 5 List of annotations

## 2 Key

### Key to abbreviations in list of legislation and annotations

Key	Explanation	Key	Explanation
AIA	= Acts Interpretation Act 1954	(prev)	= previously
amd	= amended	proc	= proclamation
amd	= amendment	prov	= provision
t			
ch	= chapter	pt	= part
def	= definition	pubd	= published
div	= division	R[X]	= Reprint No. [X]
exp	= expires/expired	RA	= Reprints Act 1992
gaz	= gazette	reloc	= relocated
hdg	= heading	renu	= renumbered
		m	
ins	= inserted	rep	= repealed
lap	= lapsed	(retro	= retrospectively
		)	
notf	= notified	rv	= revised version
d			
num	= numbered	s	= section

<b>Key</b>	<b>Explanation</b>	<b>Key</b>	<b>Explanation</b>
<b>o in c</b>	= <b>order in council</b>	<b>sch</b>	= <b>schedule</b>
<b>om</b>	= <b>omitted</b>	<b>sdiv</b>	= <b>subdivision</b>
<b>orig</b>	= <b>original</b>	<b>SIA</b>	= <b>Statutory Instruments Act 1992</b>
<b>p</b>	= <b>page</b>	<b>SIR</b>	= <b>Statutory Instruments Regulation 2012</b>
<b>para</b>	= <b>paragraph</b>	<b>SL</b>	= <b>subordinate legislation</b>
<b>prec</b>	= <b>preceding</b>	<b>sub</b>	= <b>substituted</b>
<b>pres</b>	= <b>present</b>	<b>unnum</b>	= <b>unnumbered</b>
<b>prev</b>	= <b>previous</b>	<b>m</b>	

### 3 Table of reprints

A new reprint of the legislation is prepared by the Office of the Queensland Parliamentary Counsel each time a change to the legislation takes effect.

The notes column for this reprint gives details of any discretionary editorial powers under the **Reprints Act 1992** used by the Office of the Queensland Parliamentary Counsel in preparing it. Section 5(c) and (d) of the Act are not mentioned as they contain mandatory requirements that all amendments be included and all necessary consequential amendments be incorporated, whether of punctuation, numbering or another kind. Further details of the use of any discretionary editorial power noted in the table can be obtained by contacting the Office of the Queensland Parliamentary Counsel by telephone on 3003 9601 or email [legislation.queries@oqpc.qld.gov.au](mailto:legislation.queries@oqpc.qld.gov.au).

From 29 January 2013, all Queensland reprints are dated and authorised by the Parliamentary Counsel. The previous numbering system and distinctions between printed and electronic reprints is not continued with the relevant details for historical reprints included in this table.

<b>Current as at</b>	<b>Amendments included</b>	<b>Notes</b>
10 February 2014	2014 SL No. 9	
29 September 2014	2014 SL No. 216	

<b>Current as at</b>	<b>Amendments included</b>	<b>Notes</b>
17 December 2015	2015 SL No. 188	RA s 27
6 February 2016	2015 SL No. 188	RA s 27

## 4 List of legislation

### Regulatory impact statements

For subordinate legislation that has a regulatory impact statement, specific reference to the statement is included in this list.

### Explanatory notes

All subordinate legislation made on or after 1 January 2011 has an explanatory note. For subordinate legislation made before 1 January 2011 that has an explanatory note, specific reference to the note is included in this list.

**Note—The Heavy Vehicle (Mass, Dimension and Loading) National Regulation is applied as a law of Queensland under the Heavy Vehicle National Law as applied by the Heavy Vehicle National Law Act 2012. This version is the regulation as it applies in Queensland.**

**Heavy Vehicle (Mass, Dimension and Loading) National Regulation 2013 SL No. 77**  
 made by the Queensland Governor, as defined under s 730(5) of the Heavy Vehicle National Law, acting with the advice of the Executive Council of Queensland on 30 May 2013  
 published on the NSW legislation website in accordance with Pt 6A of the Interpretation Act 1987 of NSW on 31 May 2013  
 ss 1–2 commenced on date of publication  
 remaining provisions commenced 10 February 2014 (see s 2 and 2014 SL No. 5)  
exp 1 September 2023 (see SIA s 54)  
 Note—The expiry date may have changed since this reprint was published. See the latest reprint of the SIR for any change.  
 amending legislation—

**Heavy Vehicle (Mass, Dimension and Loading) National Amendment Regulation 2014 SL No. 9**  
 published on the NSW legislation website in accordance with Pt 6A of the Interpretation Act 1987 of NSW on 31 January 2014  
 ss 1–2 commenced on date of publication  
 remaining provisions commenced 9 February 2014 (see s 2)

**Heavy Vehicle (Mass, Dimension and Loading) National Amendment Regulation 2014 SL No. 216**  
 published on the NSW legislation website in accordance with Pt 6A of the Interpretation Act 1987 of NSW on 26 September 2014

ss 1–2 commenced on date of publication  
remaining provisions commenced 29 September 2014 (see s 2)

**Heavy Vehicle National Amendment Regulation 2015 SL No. 188 pts 1, 4**

published on the NSW legislation website in accordance with Part 6A of the Interpretation Act 1987 of NSW on 17 December 2015

ss 1–2, 19–20, 25–26 commenced on date of publication (see s 2(2))  
remaining provisions commenced 6 February 2016 (see s 2(1) and 2015 SL No. 186)

## 5 List of annotations

### Definitions

s 3 def *complying steer axle vehicle* ins 2015 SL No. 188 s 19(1)  
def *HML declaration* amd 2015 SL No. 188 s 19(2)  
def *one tonne tri-axle mass transfer allowance* ins 2014 SL No. 216 s 4  
def *steer axle mass exception limits* om 2015 SL No. 188 s 19(3)  
def *UN ECE Regulation* ins 2015 SL No. 188 s 19(1)

### Prescribed mass requirements

s 6 amd 2014 SL No. 216 s 5

### Mass exceptions

s 7 amd 2014 SL No. 216 s 6; 2015 SL No. 188 s 20

### Requirements about Commonwealth Gazette Notice etc.

s 15 amd 2015 SL No. 188 s 21

### Process for amending a stated map or stated list

s 15A ins 2015 SL No. 188 s 22

### Identification requirement for particular HML heavy vehicle

s 36 amd 2015 SL No. 188 s 23

### PART 8—TRANSITIONAL PROVISIONS

pt hdg ins 2015 SL No. 188 s 24

### Saving of stated map and other matters under section 15

s 46 ins 2015 SL No. 188 s 24

### SCHEDULE 1—GENERAL MASS LIMITS

amd 2014 SL No. 9 s 4; 2015 SL No. 188 s 25

### SCHEDULE 3—Steer axle mass exception limits

om 2015 SL No. 188 s 26

### SCHEDULE 5—HIGHER MASS LIMITS

#### Application of higher mass limits to single axle or axle group

s 1 amd 2014 SL No. 9 s 5; 2015 SL No. 188 s 27

#### SCHEDULE 5A—ONE TONNE TRI-AXLE MASS TRANSFER ALLOWANCE

ins 2014 SL No. 216 s 7

**SCHEDULE 6—DIMENSION REQUIREMENTS**

**Width**

s 7 amd 2015 SL No. 188 s 28

© State of Queensland 2016